

# JR

*feel the difference!*



# PCM9X II

9-CHANNEL COMPUTER RADIO SYSTEM

**Instruction Manual**

## Contents – General Section

Section 1: Using this manual	4
Section 2: Features	5
R770 Receiver	5
R900 Receiver	5
Section 3: Component Specifications	6
Battery Charging	8
PCM9X II Transmitter Features (Front)	9
PCM9X II Transmitter Features (Rear)	10
PCM9X II Transmitter Features (Internal)	11
Control Stick Tension Adjustment	11
Advanced Digital Trims	12
Control Stick Length	12
R900S Receiver Connection Diagram	12
Direct Servo Control (DSC)	13
Neckstrap Attachment	13
Frequency Notes	14
Installation Requirements	15
Flash Memory	15
Battery Alarm and Display	15
System Mode – Functions Common to GLIDER, ACRO and HELI model types	16
System mode contains the follow screens:	16
Model Select / Copy	17
Model Name	18
Type Select	18
Model Reset	19
Modulation	19
Transfer – Transfer the model to another transmitter or to DataSafe	20
Transfer a model from the PCM9X II – (Transfer function)	20
Transfer a model to the PCM9X II – (Transfer function)	21
Stick Mode	22
Stick Direction	23
FUNCTION MODE - Functions Common to GLIDER, ACRO and HELI model types	24
Throttle Cut and Trim Select	24
TRAINER – Trainer System	25
PCM9X II used as Master (Instructor) – (Trainer System)	25
PCM9X II used as Slave (Student) – (Trainer System)	26
Fail Safe	27
Dual Rates and Exponential Curves	28

Sub Trim Usage and Mechanical Advantage	29
Servo Precautions	30
General notes	31
Aviation Regulations	32
Daily Flight Checks	32
Warranty Information	33

## Section 1: Using this manual

---

This Manual is divided into three specific sections: Airplane, Sailplane and Helicopter.

In this manual you will find the specifications for the radio and its various components and accessories. In addition, guidelines for the installation have been included. Instructions for setting all the functions and programs are presented in the three sections of the manual: Airplane, Sailplane and Helicopter. These features are discussed in the same order that they

would normally be needed to set up a typical aircraft, 6 servo winged sailplane and helicopter respectively. An explanation of the use and purpose of each feature is provided, followed by a labeled illustration of its respective LCD display.

A blank data sheet has been included at the end of each section. Once all data has been input for a particular model, it is highly recommended that you record it on a copy of the sheet provided.

## Section 2: Features

---

The computer-designed, ergonomically-styled transmitter case ensures a comfortable fit in your hands. You will also be introduced to our exclusive "Rolling Selector" on the face of the transmitter for fast and effortless movement through any programming sequence.

The ultra-precision control sticks offer adjustable spring tensions and length. The throttle stick offers a ratchet in

Airplane/Sailplane configuration. Stick modes 1-4 are menu selectable.

30-model memory storage allows programming of all parameters of thirty separate airplanes, sailplanes or helicopters; you can program more than one setup for a single aircraft, allowing you to instantly change the flight characteristics.

### R770 Receiver

---

#### R770 (Basic Air and Sailplane Systems)

The R770 is a high-performance 7 channel PCM single-conversion receiver with 10KHz super narrow band ABC&W circuitry.

A narrow band ceramic filter for high-signal selectivity assists in rejecting cross modulations from other

common radio frequencies, such as RC transmitters or local paging systems.

This receiver features Direct Servo Control (DSC) for control of servos without radio frequency output.

The receiver has low current consumption.

The R770's Slimline design allows it to fit into most model applications.

### R900 Receiver

---

#### R900 (Advanced Air, Basic & Advanced Helicopter Systems)

The R900 is a high-performance 9 channel PCM single-conversion receiver with 10KHz super narrow band ABC&W circuitry.

A narrow band ceramic filter for high-signal selectivity assists in rejecting cross modulations from other

common radio frequencies, such as RC transmitters or local paging systems.

This receiver features Direct Servo Control (DSC) for control of servos without radio frequency output.

The receiver has low current consumption.

The R900's credit card size design allows it to fit into most model applications.

## Section 3: Component Specifications

---

### Component Specifications

Type	Airplane
System Name	PCM9X II
Transmitter Body	NET-N239ES
Receiver	R900
Charger	NEC-322AUS
Airborne Battery	1100mah
Servos	4 ea ES539
Accessories	Deluxe Switch Servo Accessories Hex Wrench Instruction Manual

### Transmitter Specifications

Type	Airplane
Model Number	NET-N239ES
Encoder	9-channel computer system
RF Module	Plug-in-Module
Modulation	PPM / SPCM / ZPCM
Output Power	Approximately 750mw
Current Drain	200ma
Power Source	1.2Vx8 Ni-Cd (9.6V) 600Mah
Output Pulse	1000-2000 (1500 neutral)

### Receiver Specifications

Type	7 Channel SPCM	9 Channel SPCM
Model Number	R770	R900
Type	7-ch/SPCM- ABC&W/Micro	9-ch/SPCM-ABC&W
Sensitivity (Microseconds)	5uS Minimum	5uS Minimum
Selectivity	8KHz/5 dB	8KHz/5 dB
Weight gm	20 gm	28 gm
Receiver Antenna	39"/99cm for all aircraft frequencies	39"/99cm for all aircraft frequencies

## Servo Specifications

Type	ES-539
Torque	4.8kg.cm
Speed	0.23 sec
Weight	38 gm
Size mm (L x W x H)	32.5 x 19 x 38.5 mm
Ballbearing	Yes
Motor	Ferrite

## Airborne Battery Pack Specifications

Type	Airplane
Model Number	B1100
Voltage	4.8V
Capacity	1100 mAH
Size (in) (L x W x H)	2.24 x 0.53 x 1.70
Weight (oz)	4.9

## Charger Specifications

Type	Airplane
Model Number	NEC-322AUS
Input Voltage	AC 240V
Output Current	50 mA Tx/100 mA Rx
Charging Time	15 Hours

# Battery Charging

## Transmitter/Receiver

Note: It is imperative that you fully charge both the transmitter and the receiver battery packs prior to each trip to the field. To do so, leave the charger and batteries hooked up overnight (16 hours). The first charge should be approximately 20–24 hours in order to fully charge both battery packs to peak capacity.

The charger supplied with this system is designed to recharge your batteries at a rate of 65mAh for the transmitter and 150mAh for the receiver battery pack.

## Transmitter Only

The center pin on all JR® Remote Control Systems is negative. Therefore, the center pin on all JR chargers is negative, not positive. This is different from many other manufacturers' chargers and radio systems. Beware of improper connections based on "color-coded" wire leads, as they do not apply in this instance. You must make sure that the center pin of your JR transmitter is always connected to the negative voltage for correct polarity hookup.

Important: Please note that the charging polarity of the transmitter and receiver are different.

## Charger

The pilot lamps should always be on during the charging operation. If not, check to make sure that both the transmitter and receiver are switched off.

Do not use the charger for equipment other than JR. The charging plug polarity may not be the same. Equipment damage can result.

Do not use other manufacturers' after-market accessories that plug into the transmitter's charging jack if you are unsure of compatibility issues with your radio. Seek expert advice to avoid possible damage.

During the charging operation, the charger's temperature is slightly elevated. This is normal.

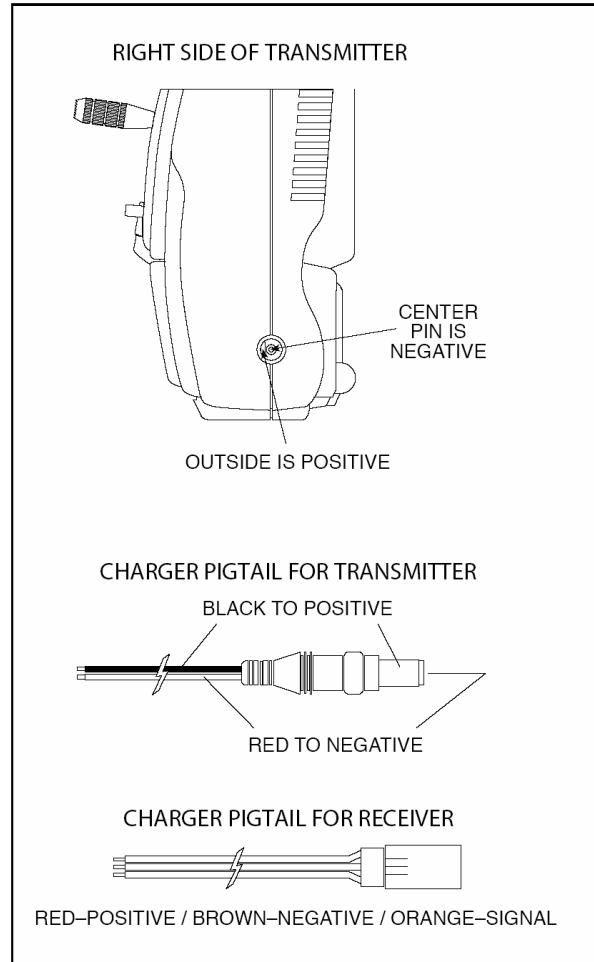

# PCM9X II Transmitter Features (Front)

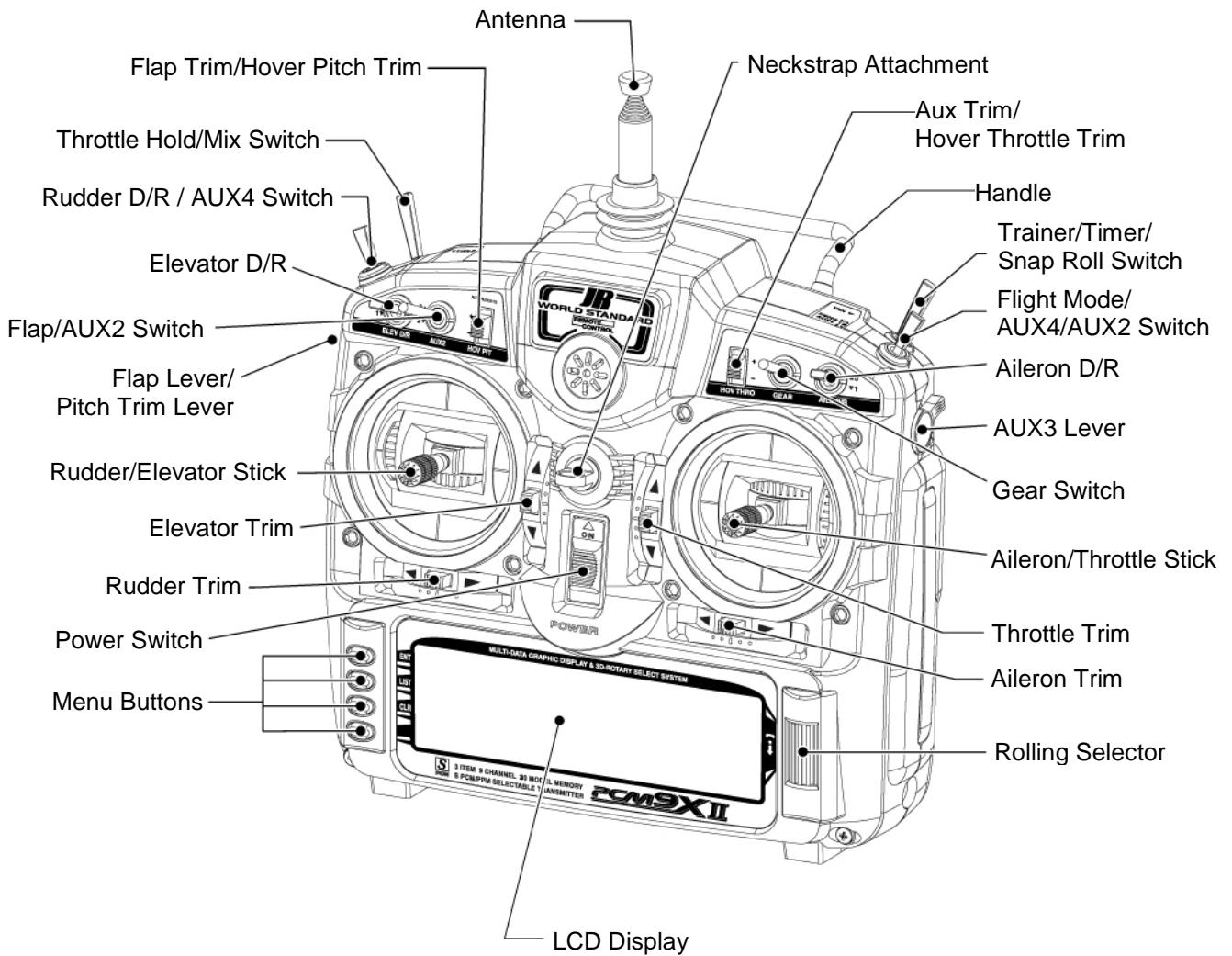

Transmitter shown with stick mode 1 selected

Switch Labels	Airplane Menus	Sailplane Menus	Heli Menus
RUDD D/R / AUX4	RUD D/R	RUD D/R	RUD D/R
T.HOLD / MIX	MIX SW	BTFL SW	HOLD SW
ELEV D/R	ELE D/R	ELE D/R	ELE D/R
FLAP / AUX2	FLAP SW	AUX4 SW	AUX2 SW
GEAR	GEAR SW	MOTO S/W	GEAR SW
AILE D/R	AIL D/R	AIL D/R	AIL D/R
F.MODE / AUX4 / AUX2	AUX2 SW	FMOD SW	FMOD SW
(Spoiler Stick)		SPOI ST	
TRN / SN ROLL	SNAP SW	TIME SW	
(Menu Button)		TIM KEY	
(Left Side Lever)	FLAP LV	FLAP LV	Pit.T LEV
(Right Side Lever)	AUX3 LV	AUX3 LV	AUX3 LEV

Switch Naming in the Menus

## PCM9X II Transmitter Features (Rear)

---

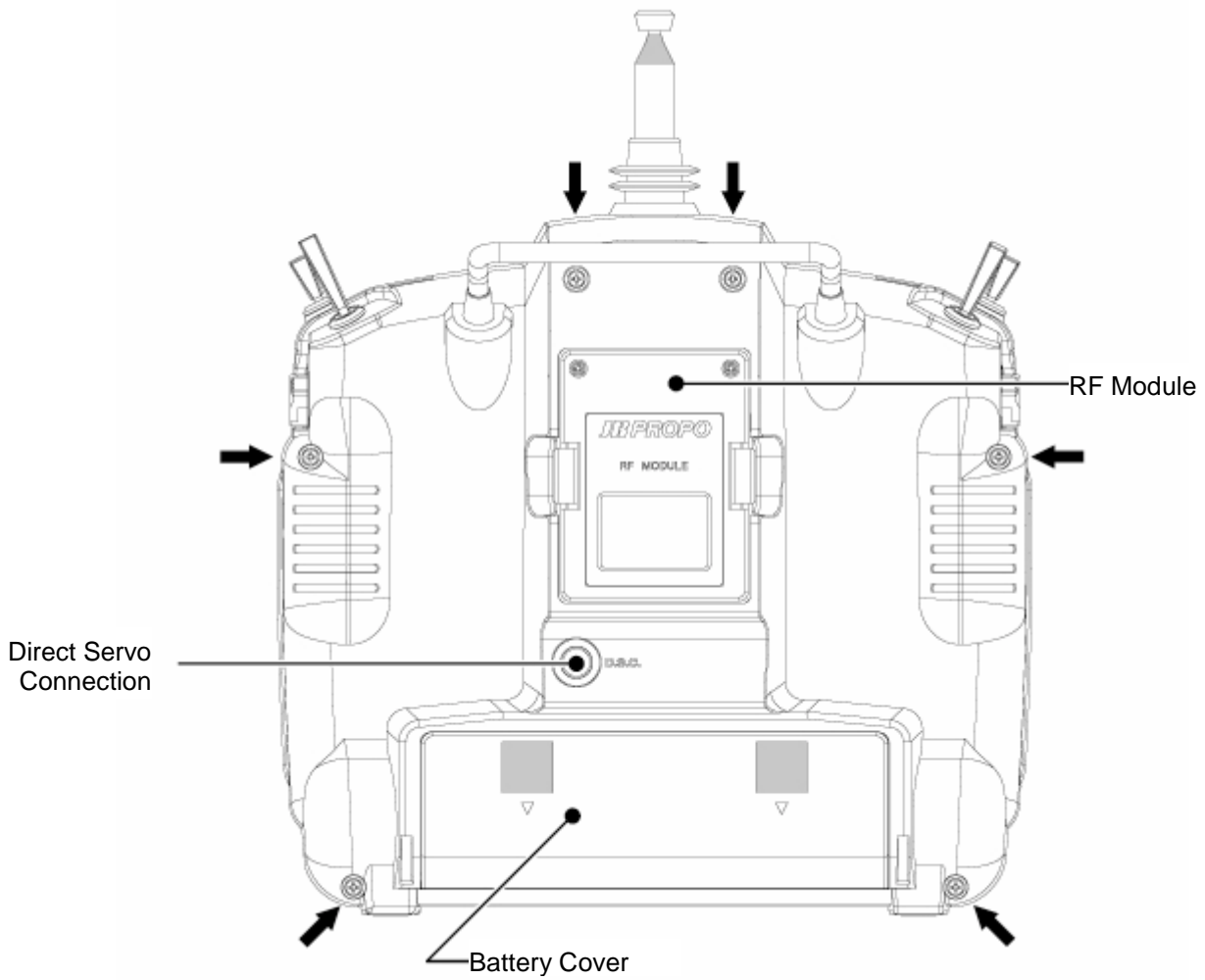

CAUTION: THE BATTERY CONNECTION IS KEYED SO THAT IT CAN ONLY BE PLUGGED IN ONE DIRECTION.  
DO NOT FORCE

## PCM9X II Transmitter Features (Internal)

---

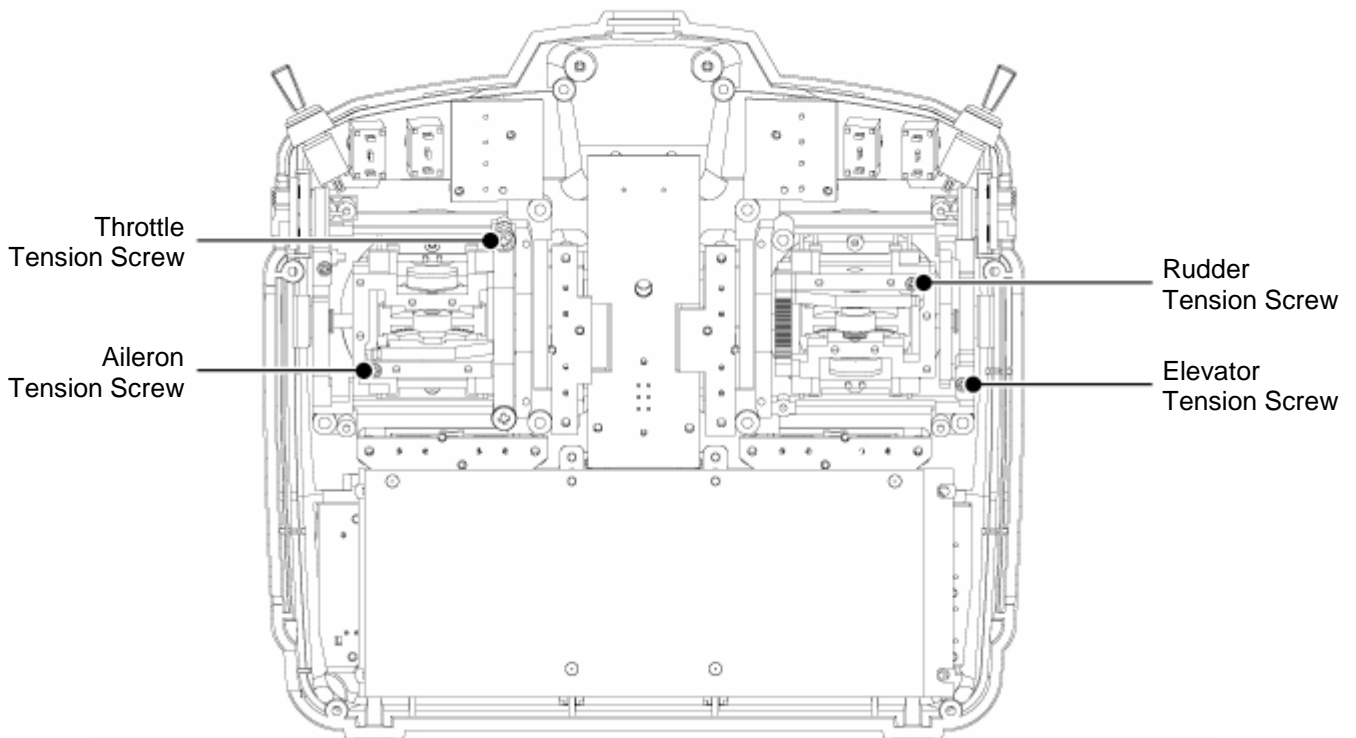

### Control Stick Tension Adjustment

---

Remove the six transmitter back screws as shown on the previous page. Remove the transmitter back, being careful not to cause damage to any components.

Adjust each screw for desired tension (counter-clockwise to loosen stick feel; clockwise to tighten stick feel). When adjusting the throttle ratchet tension, make sure that the adjusting screw does not touch the PC board after adjustment is complete.

## Advanced Digital Trims

The PCM9X II's digital trims feature the Direct Access display function. While at the Normal display screen, if a trim lever is moved, the screen will automatically change to display the graphic position for the trim being adjusted. The PCM9X II's Aileron, Elevator, Throttle and Rudder trim levers feature an audible center trim beep. This is helpful in determining the trim levers center position during flight.

By using the Trim Step Function located in the System Mode, the movement of the ADT trims can be fine tuned as needed to match your specific application

Please also note that unlike conventional mechanical trim levers, when the PCM9X II transmitter is in the off position, no changes can be made to the trim values during transportation.

## Control Stick Length

To adjust the stick length, use the 2mm Allen wrench (supplied with your PCM9X II transmitter) to unlock the set screw. Turn the wrench counter-clockwise to loosen the screw. Then, turn the stick clockwise to shorten or counterclockwise to lengthen. After the control stick length has been adjusted to suit your flying style, tighten the 2mm set screw.

If you desire longer sticks, JR® offers a stick (JRPA047) that is approximately one inch longer than standard. This stick, crafted from bar stock aluminum, is available at your local JR dealer.

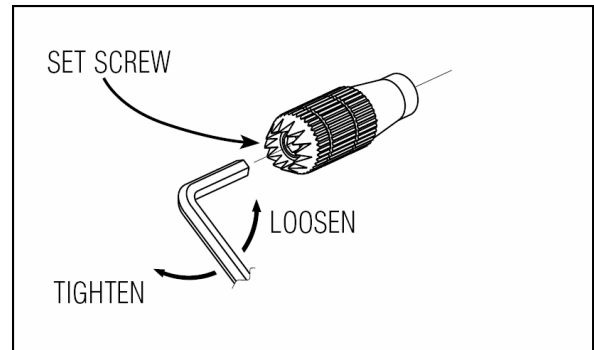

## R900S Receiver Connection Diagram

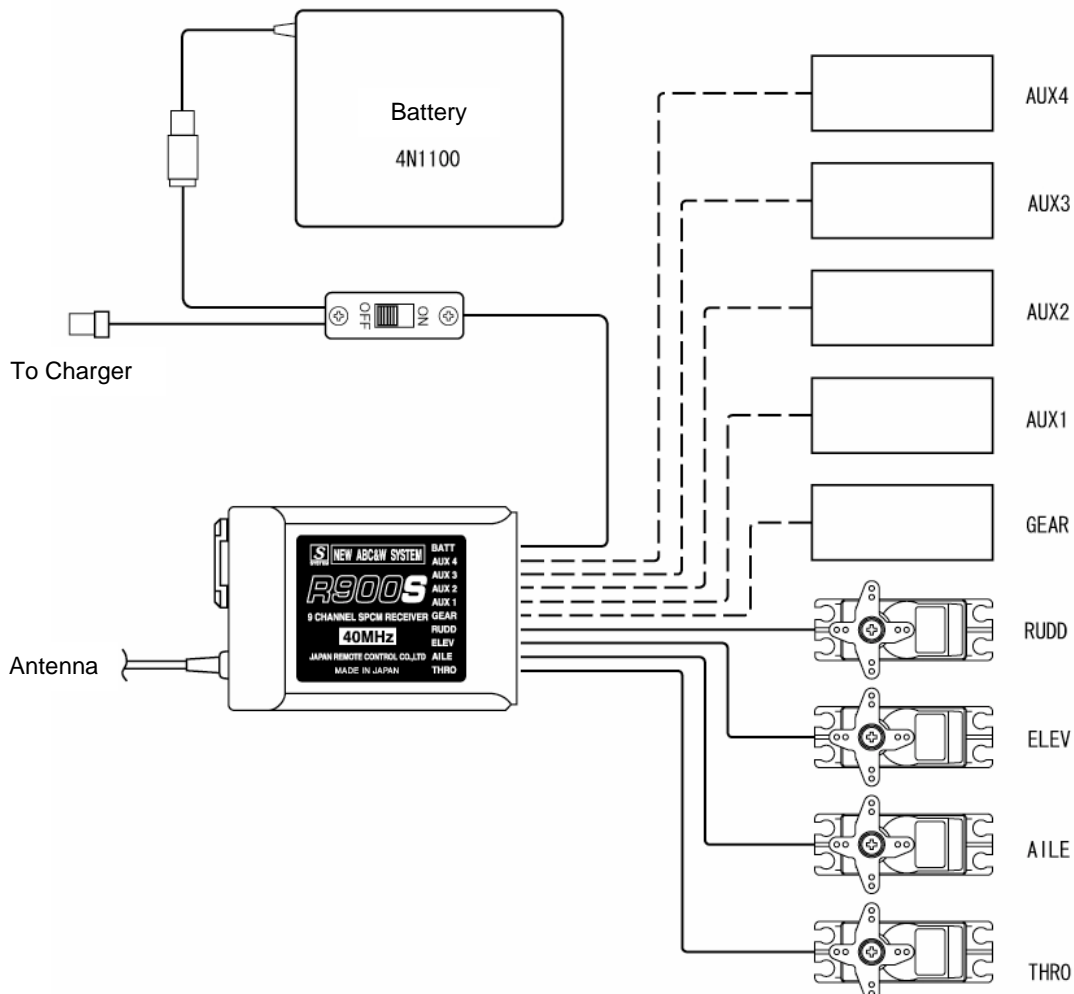

## Direct Servo Control (DSC)

For proper DSC hook-up and operation:

1. Leave the transmitter power switch in the Off position. The transmitter will not transmit any radio frequency (RF) in this position.
2. Plug the DSC cord (purchased separately, JRPA132) into the DSC port in the rear of the transmitter.
3. The encoder section of the transmitter will now be operational and the LCD display will be lit.
4. Plug the other end of the DSC Cord into the receiver charge receptacle. (You must use a 3-wire switch harness, such as the Deluxe Switch Harness – JRPA001, or a JR Charge switch – JRPA004, for the DSC function to work.) Turn the switch harness to the On position.

Note: When you install the charging jack, be sure to hook the charging jack receptacle securely into the switch harness charge cord.

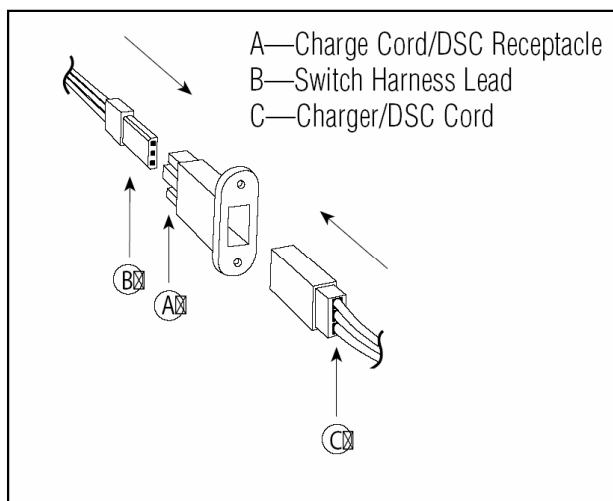

### Why you should use the DSC function:

1. The DSC enables you to check the control surfaces of your aircraft without drawing the fully operational 200mAh from your transmitter battery pack. Instead, you will only draw approximately 70mAh when using the DSC function.
2. The DSC function allows you to make final adjustments to your airplane without transmitting any radio signals. Therefore, if another pilot is flying on your frequency, you can still adjust your aircraft and not interfere with the other pilot's aircraft. This is also a tremendous tool to use in the original setup of your aircraft while still in the workshop. Because of the lower current draw on your transmitter, your working time at the bench will be extended between charges.

**Note:** This function is for bench-checking your aircraft only.



JRPA004 Charge Switch

## Neckstrap Attachment

An eyelet is provided on the face of the PCM9X II transmitter that allows you to connect a Neck Strap (JRPA023). This hook has been positioned so that your

transmitter has the best possible balance when you use the neck strap.

## Frequency Notes

---

The PCM9X II transmitter employs a plug-in module for the transmitter. The PCM9X II can transmit in either Pulse Code Modulation (SPCM or ZPCM) or Pulse Position Modulation (PPM, commonly referred to as FM).

Be certain to observe the following guidelines:

Do not operate your transmitter when another transmitter is using the same frequency, regardless of whether the second transmitter is PCM, PPM (FM) or AM. You can never operate two transmitters on the same frequency simultaneously without causing interference.

## Installation Requirements

---

It is extremely important that your radio system be correctly installed in your model. Here are a few suggestions for installing your JR® equipment:

1. Wrap the receiver in protective foam rubber that is no less than 1 cm inch thick. Secure the foam to the receiver with rubber bands. This protects the receiver in the event of a crash or a very hard landing.
2. The servos should be mounted using rubber grommets and brass eyelets to isolate them from vibration. Do not over-tighten the mounting screws; this will negate the vibration absorption effect of the rubber grommets. The following diagram will assist you in properly mounting your servo.  
The brass eyelets are pushed from the bottom up in the rubber grommets. When the servo screw is tightened securely, it provides the proper security as well as the proper vibration isolation for your servo.
3. The servos must be able to move freely over their entire range of travel. Make sure that the control linkages do not bind or impede the movement of any of the servos.

4. Mount all switches away from the engine exhaust and away from any high vibration areas. Make sure the switch operates freely and is able to operate over its full travel.
5. Mount the receiver antenna firmly to the airplane to ensure that it will not become entangled in the propeller or control surfaces.

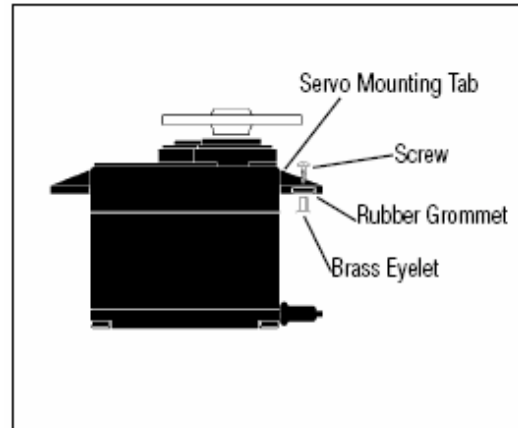

## Flash Memory

---

All preprogrammed data is protected by a flash memory that guards against main transmitter battery failure.

## Battery Alarm and Display

---

When the transmitter voltage drops below 9.0 volts DC, the display flashes "BATT LOW" and an alarm sounds.

If you are flying when this occurs, land immediately.

## System Mode – Functions Common to GLIDER, ACRO and HELI model types

System mode contains the foundational programming. System mode screens include model name, model reset, modulation, data transfer, etc.—functions that are typically set once and then are seldom changed or

adjusted. This section describes the system functions that are common to all 3 model types. System functions that are specific to each model type are covered in the each of the glider, acro and heli sections.

### To enter System Mode—

Press ENT and hold while turning on the transmitter. The screen should appear as follows.

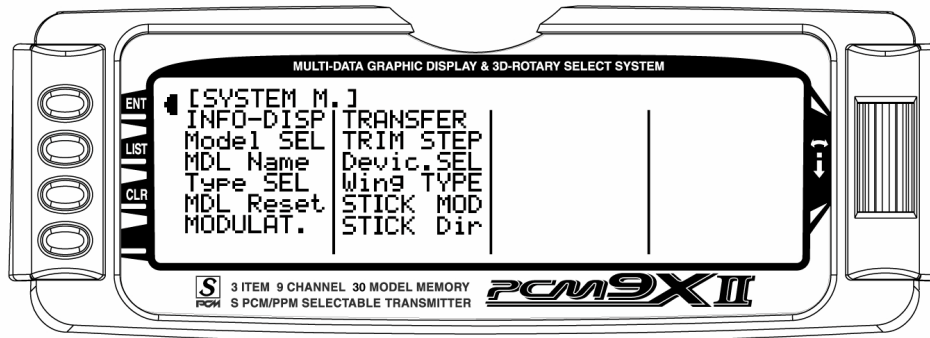

Note: In HELI mode the Wing Type function is replaced by the Swash Type function.

### System mode contains the follow screens:

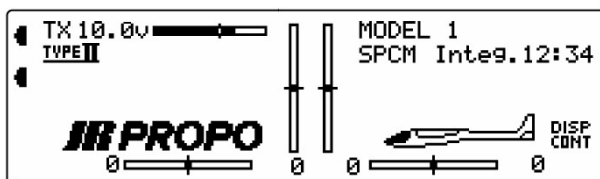

Info Display



Modulation Pg. 19

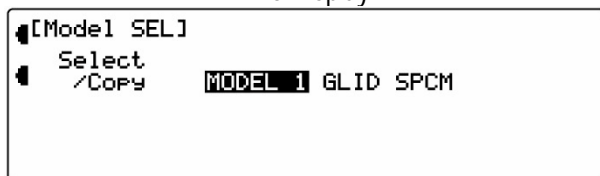

Model Select / Copy Pg 17

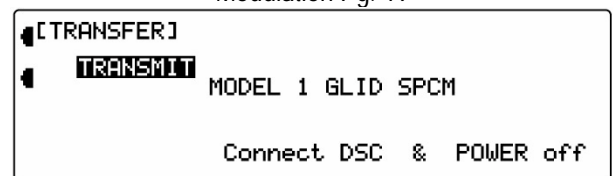

Transfer Pg 20

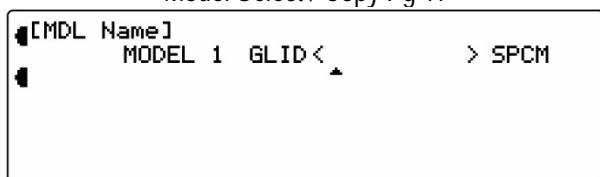

Model Name Pg 17

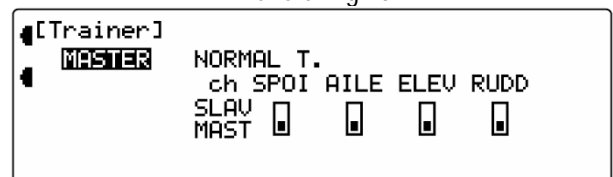

Trainer Pg 22



Type Select Pg. 18

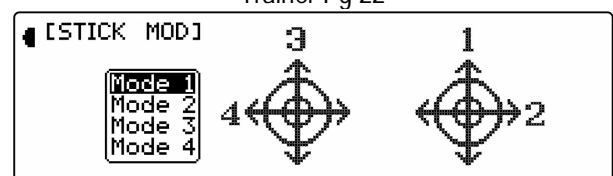

Stick Mode Pg 22

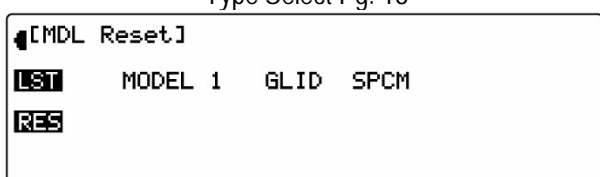

Model Reset Pg. 19

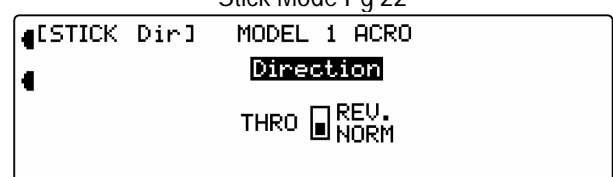

Stick Direction Pg 22

## Model Select / Copy

Model select allows up to 30 different models to be stored and selected.

**Note:** When setting up a new model it is recommended that an unused model memory is selected. If a current model memory is selected it's recommended that the model be reset to factory default setting before programming the new model. See model reset on page 19.

### Model Select

1. In the **SYSTEM Menu**, highlight and select **Model SEL** using the Selector.
2. Use the Selector to highlight and select the desired model number to be used.
3. Return to the **SYSTEM Menu** by pressing the LIST button.

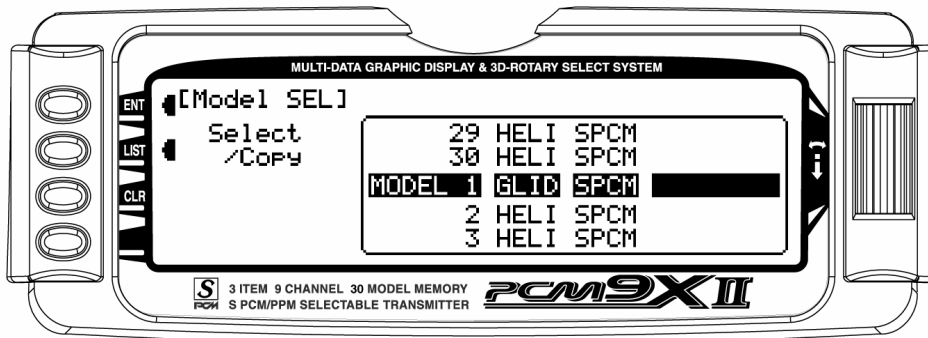

### Copy Function

1. Highlight and select **Model SEL** in the **SYSTEM Menu**. Then highlight and select **Select** to obtain the Copy display. The display shows the currently selected model on top with a down-arrow pointing to the lower model memory that the current model will be copied into.

To change the lower model memory that is to receive the copy of the current model, highlight and select the lower model name and number. Then scroll to an unused model memory or a memory that contains data that is no longer required, and select it.

2. Verify that the top model is the model that is to be backed-up and the lower model is empty or contains a model that is no longer required. When satisfied that all is well, press the **CLR** button on the left side of the display next to **COPY**. The entire contents of the currently selected model is copied to the lower model on the display and there is now a complete backup of the current model. The upper and lower model memory names are now the same because the two model memories are now identical in every regard.

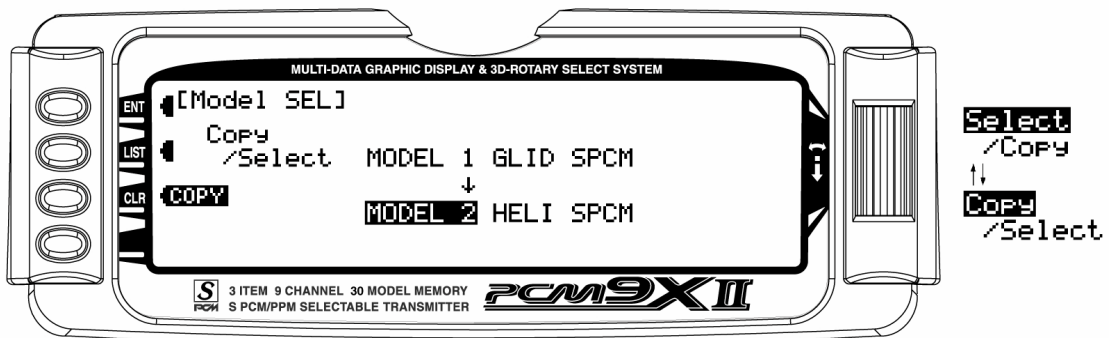

## Model Name

The model name screen allows each model to be given an eight digit name or number. This is convenient for identifying a model or the channel number the model is on. The model's name will appear in the upper right corner of the main info screen.

1. In the **SYSTEM Menu**, highlight and select **MDL Name** using the Selector.
2. The cursor (indicates where the next character will be placed) is positioned at the beginning of the

model name. Press the Selector to obtain a list of available characters.

3. Highlight and select the desired character to form the model name. After the character is selected, rotate the Selector to position the cursor where the next character is to be placed and press the Selector to obtain the character list again. Repeat until the model name is completed.
4. Return to the SYSTEM Menu by pressing the LIST button.

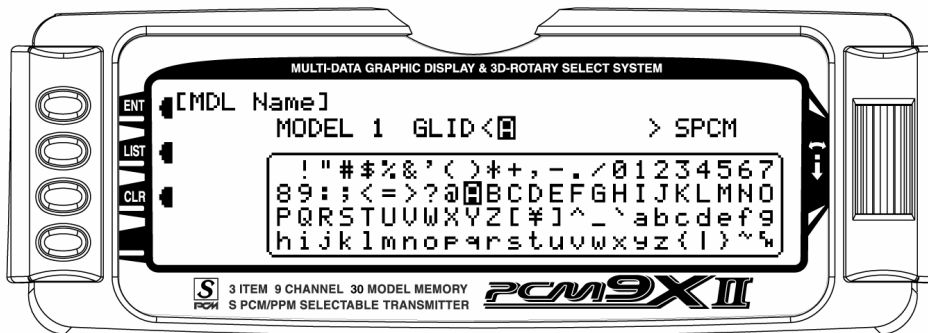

## Type Select

Type select allows the model type to be selected. Model types include glider, acro or heli. **Note:** When changing model types the programming information will be reset to the factory default setting losing the previous settings.

1. In the **SYSTEM Menu**, highlight and select **Type SEL** using the Selector.
2. Highlight and select the desired model type using the Selector.
3. Return to the SYSTEM Menu by pressing the LIST button.

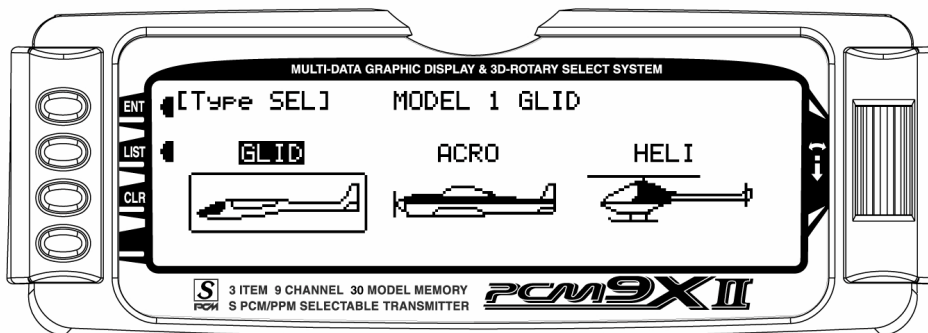

## Model Reset

---

Model Reset is used to return the program to the factory default settings.

1. In the **SYSTEM Menu**, highlight and select **MDL Reset** using the Selector.
2. Press the CLR button that is next to **RES** on the display.

3. Press the lowermost button next to YES on the display to reset all data for this model.
4. Return to the SYSTEM Menu by pressing the LIST button.

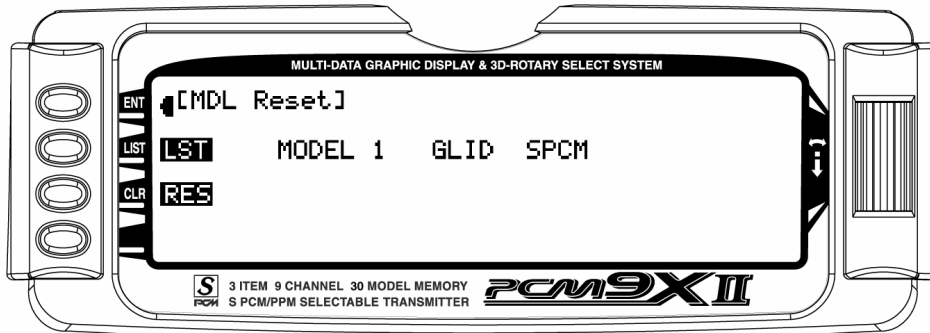

## Modulation

---

The PCM9X II system supports three types of modulation – ZPCM, SPCM and PPM (FM). The correct modulation type must be selected to match the receiver in the aircraft or the system will not function.

1. In the **SYSTEM Menu**, highlight and select **MODULAT.** using the Selector.

2. Highlight and select either **ZPCM** or **SPCM** or **PPM** to match the receiver in the aircraft.
3. Return to the SYSTEM Menu by pressing the LIST button.

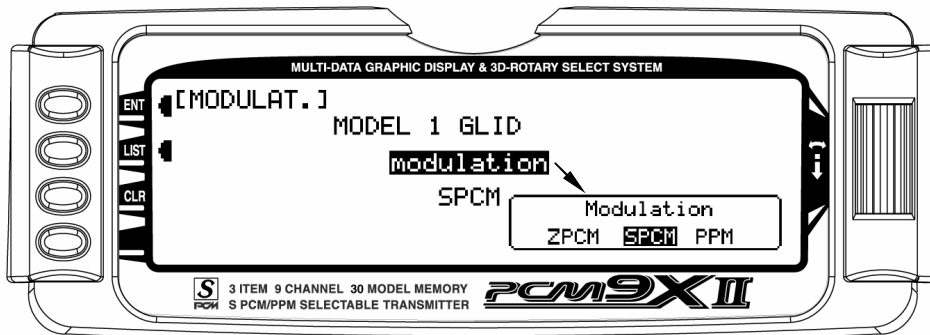

## Transfer – Transfer the model to another transmitter or to DataSafe

The TRANSFER function can be found in the **SYSTEM Menu** and is used to copy the contents of a model memory to another PCM9X II transmitter or to a DataSafe device on a Personal Computer (PC). It is

also used to receive data for a model, either from another PCM9X II transmitter or from a DataSafe unit.

### Transfer a model from the PCM9X II – (Transfer function)

1. Hold the **ENT** button while plugging the trainer cord into the back of the transmitter to obtain the **SYSTEM Menu**.

Plug the other end of the trainer cord into another PCM9X II transmitter while holding the ENT button down and prepare that transmitter for Receive as

described below. Or, plug the other end of the trainer cord into a DataSafe unit and prepare the DataSafe to receive.

2. Highlight and select **TRANSFER** in the **SYSTEM Menu** to obtain the Transfer display.

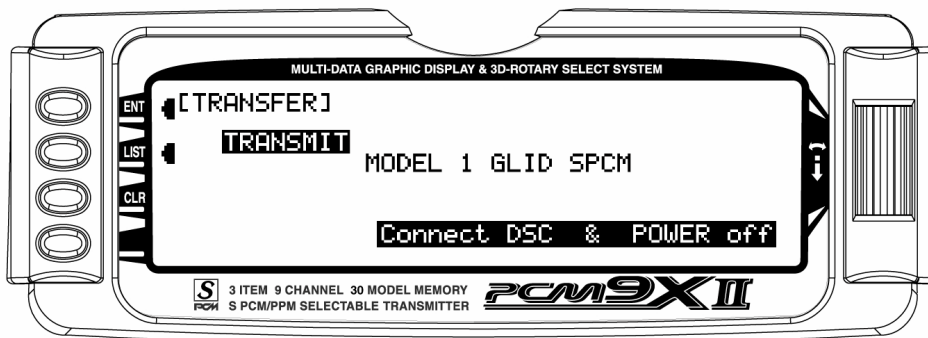

3. The model to be transferred must be the currently selected model. If the model to be transferred is not currently selected, see **Model SEL** in the **SYSTEM Menu** to select the model to be transferred to another PCM9X II or DataSafe unit.

4. When the receiving device is ready, press the CLR button next to **START** on the left side of the display. The data for the currently selected model is transferred to the receiving device.

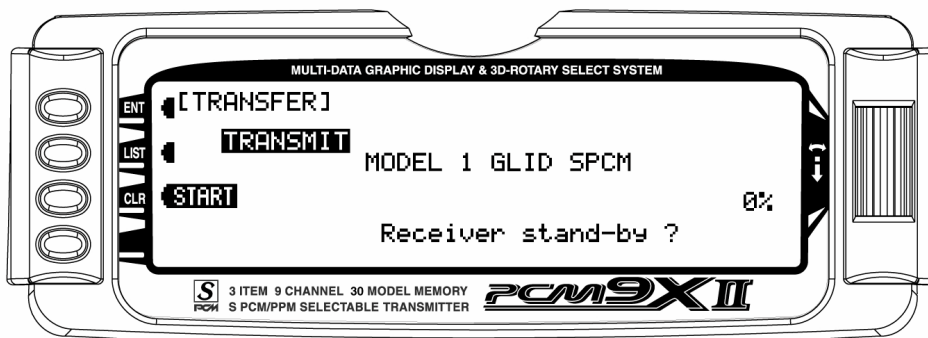

## Transfer a model to the PCM9X II – (Transfer function)

1. Hold the **ENT** button while plugging the trainer cord into the back of the transmitter to obtain the **SYSTEM Menu**. Plug the other end of the trainer cord into another PCM9X II transmitter while holding the **ENT** button and prepare that transmitter for Transmit as described above. Or, plug the other end of the trainer

cord into a DataSafe unit and prepare the DataSafe to transmit.

2. Highlight and select **TRANSFER** in the **SYSTEM Menu** to obtain the Transfer display.

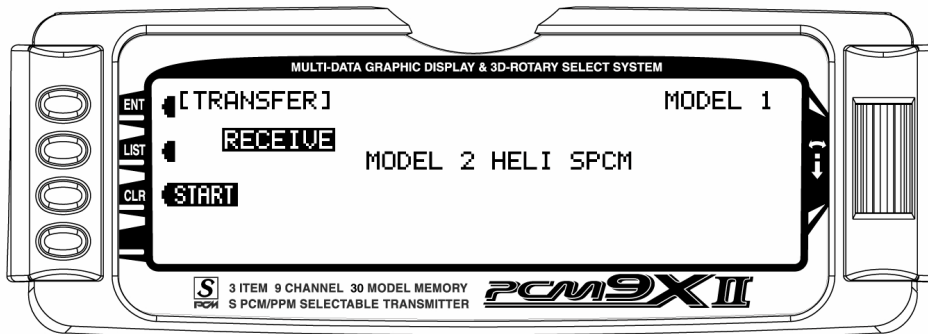

3. If **RECEIVE** is already displayed, continue with the next step. If **TRANSMIT** is displayed, highlight and select **TRANSMIT**, changing it to **RECEIVE**.

4. Select the model memory to receive the data by highlighting and selecting the model name/memory number and then scrolling to and selecting the model memory that is to receive the data. Be careful to select an unused model memory or a memory that contains data for a model no longer needed because the data in this model memory is going to be

replaced by what is transmitted and will be permanently lost.

5. Press the **CLR** button next to **START** on the left side of the display. Stand-by appears at the bottom of the display indicating that the PCM9X II is ready to receive data. Press start on the transmitting PCM9X II or DataSafe unit to begin the data transfer to the PCM9X II.

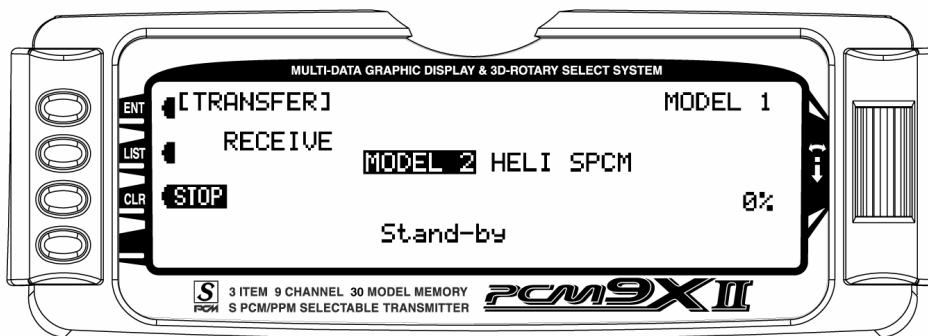

## Stick Mode

The Mode of the sticks can be chosen with this function. You can choose from Mode 1, 2, 3 or 4. The transmitter comes set to Mode 1 which is the most common mode in Australia. If Mode 2 or Mode 4 are chosen you will need to remove the back of the transmitter cover and swap the throttle ratchet and elevator spring.

1. From **SYSTEM M**, highlight and select **STICK MOD** using the Selector.
2. Highlight and select the current mode. A list of available modes 1 – 4 will appear. Highlight and select the desired mode.

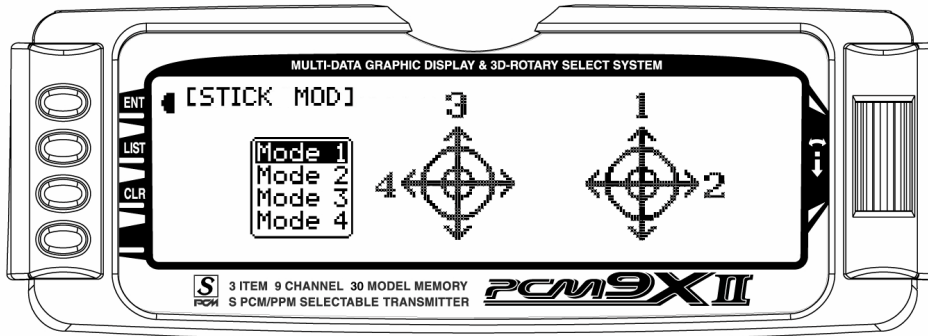

Mode 1	3 – Elevator 4 – Rudder	1 – Throttle/Spoiler 2 – Aileron
Mode 2	1 – Throttle/Spoiler 4 – Rudder	3 – Elevator 2 – Aileron
Mode 3	3 – Elevator 2 – Aileron	1 – Throttle/Spoiler 4 – Rudder
Mode 4	1 – Throttle/Spoiler 2 – Aileron	3 – Elevator 4 – Rudder

## Stick Direction

This function sets the direction of the Throttle stick for idle. The transmitter defaults to have idle (low motor) with the stick pulled back or down.

1. From **SYSTEM M.** highlight and select **STICK Dir** using the Selector.
2. Highlight **Direction** and press the Selector to reverse the idle position.

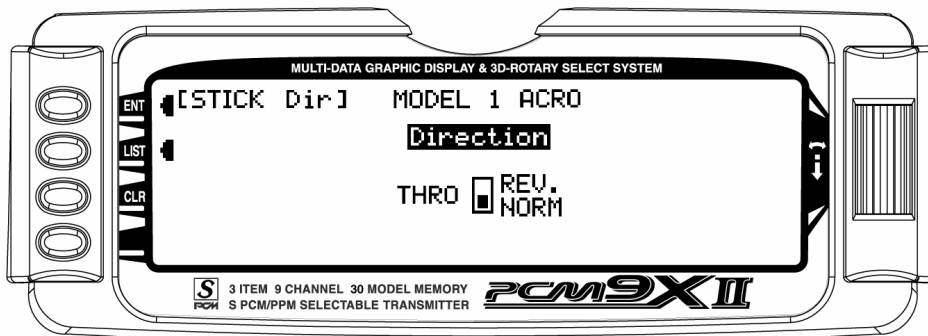

In Glider mode, this function sets the direction of the Spoiler stick.

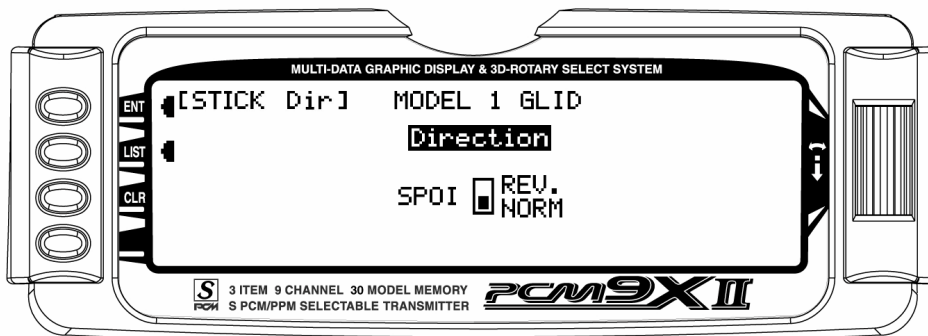

## FUNCTION MODE - Functions Common to GLIDER, ACRO and HELI model types

Programs found in the function mode are more frequently used. Not only are these functions used during initial setup, but many of these are commonly adjusted at the field to change/optimize the flight characteristics and response of an aircraft.

To enter function modes, turn on the transmitter then press the ENT button. To enter the function list mode,

press the list mode after the function mode has been selected

This section describes the functions that are common to all 3 model types, ie. the Trainer and Fail safe functions, and the Throttle Cut and Trim Select function common to the Heli and Acro functions. Functions that are specific to each model type are covered in the each of the glider, acro and heli sections.

### Throttle Cut and Trim Select

The PCM9X II features an intelligent throttle trim as well as a throttle cut function. One or the other can be

activated at a time. The throttle cut function turns the trainer switch into an engine kill switch.

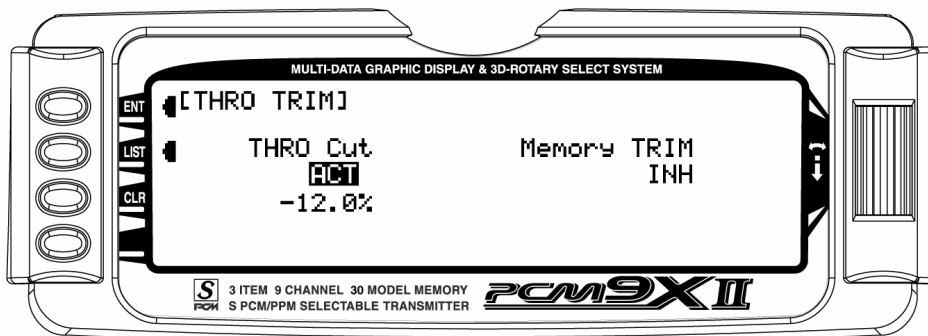

The trim select allows the throttle trim to remember a predetermined position. When a good idle point is found with the trim, activate the trim memory. This allows

stopping of the engine with the throttle trim, but one click forwards on the trim will return the digital trim to the predetermined idle position.

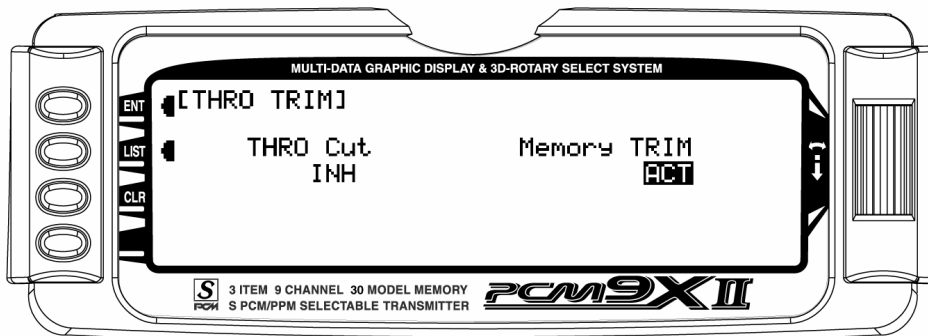

## TRAINER – Trainer System

The PCM9X II contains a Trainer System that allows the instructor to transfer some or all of the primary flight control functions (Throttle, Aileron, Elevator and Rudder) to the student. It also allows for indicating if the transmitter (TX) is to be the Master (controlled by the instructor) or Slave (controlled by the student). The Snap Roll button is used to transfer control to the student when the PCM9X II is being used as the Master/Instructor transmitter.

All Dual rates and Exponential settings in the Master TX are transferred to the Slave TX. The Slave TX battery must be charged.

1. Connect the Trainer cord between the Master and Slave transmitters. Turn the power on to the Master transmitter (the Slave TX remains powered off and can even have the module removed).
  2. Make sure the Slave TX is in the PPM/FM modulation mode. See **MODULAT** in the **SYSTEM Menu** if the Slave TX is a PCM9X II or refer to the owners manual if the TX is not a PCM9X II.
1. Highlight and select **Trainer** in the **FUNC.LIST** to obtain the Trainer Display.

## PCM9X II used as Master (Instructor) – (Trainer System)

1. If the PCM9X II is being used as the Master TX (the TX operated by the instructor), select the channel(s)

that are to be operated by the Slave TX (TX operated by the student) when the trainer switch is depressed.

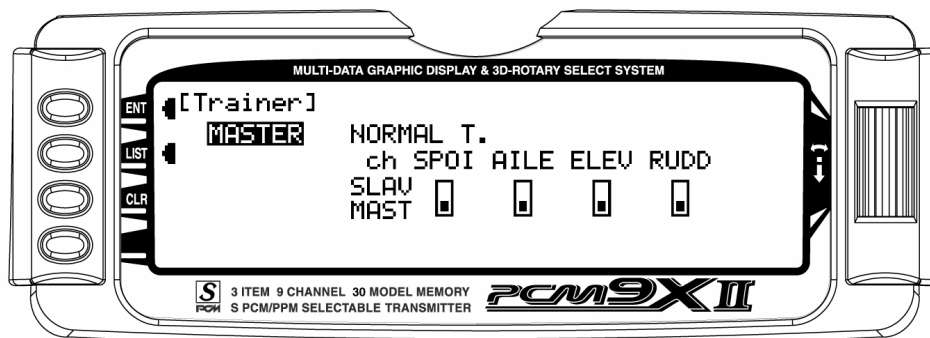

When all channel selectors are in the MAST position, **NORMAL** appears on the display and all 4 channels are transferred to the student when the trainer switch is depressed.

If only certain channels are to be transferred to the student, highlight and select the channels that are to be transferred, moving the indicator for these channels to the SLAV position for these channels. When less than

all channels are selected as SLAV, **PROGRAM T** appears on the display indicating that the Trainer System has been programmed to transfer only selected channels.

The PCM9X II is now ready to be used as the Master or instructor TX. Depress the Snap Roll button to transfer control to the student. Control will remain transferred until the Snap Roll button is released.

## PCM9X II used as Slave (Student) – (Trainer System)

1. If the PCM9X II is to be used as the Slave TX (TX used by the student), be sure that the currently selected model is set to PPM Modulation (see

MODULAT in the **SYSTEM Menu** if the Slave TX is a PCM9X II).

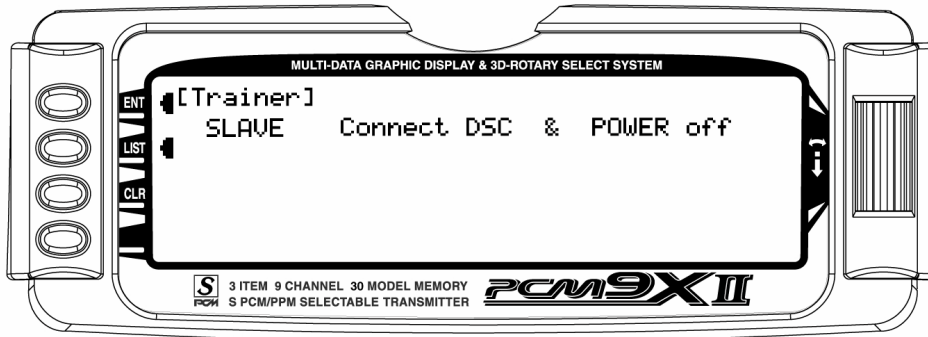

2. Highlight and select **MASTER** and the display will switch to **SLAVE**. A message will appear instructing to **Connect DSC & POWER off**. Make sure the TX

power switch is in the Off position and the DSC cord is connected between the 2 transmitters.

The PCM9X II is now ready to be used as the Slave or student TX.

## Fail Safe

Fail Safe is available only when SPCM has been selected as the **Modulation Type** in the **SYSTEM Menu**. The receiver must be of the PCM variety, as Fail Safe does not function in the PPM/FM mode.

When interference occurs on the frequency of operation, PCM receivers do not pass the interference on to the servos. Instead, the receiver commands the servos to either hold their last good position (HOLD) or to move to a pre-determined position (FAIL SAFE). Both options exist for each channel and the settings are adjustable in the Fail Safe function.

Many experienced pilots designate all channels as HOLD, except for the throttle—it is commanded to assume a Fail Safe position that corresponds to idle. In this configuration the aircraft will continue to do whatever it was doing before the interference occurred, except the throttle will reduce to idle. The servos will continue to hold their last position and the throttle will

remain at idle until the interference subsides, at which time normal operation is resumed.

More often than not, the pilot will not realize the system went into Fail Safe except for hearing the throttle momentarily reduce RPM. This is also a good configuration if interference is encountered while the aircraft is on the ground because the throttle reduces to idle, reducing the chances of the aircraft careening out of control at a higher throttle setting. In the event that the interference does not subside and the system remains in Fail Safe, it is better for the aircraft to crash with the engine at idle than at a higher throttle setting.

1. Run the engine in the aircraft and adjust the throttle stick/travel and trim so the engine has a dependable idle—perhaps a click or 2 above low idle. Leave the throttle and trim in these positions.
2. Access the Fail Safe function by highlighting and selecting **Fail Safe** in the **FUNC.LIST**.

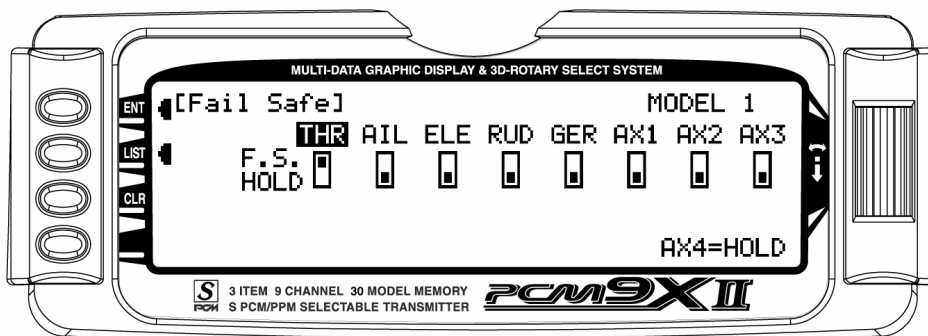

3. Highlight and select **THR**, moving its indicator from the **HOLD** position to the **F.S.** (Fail Safe) position. This instructs the Fail Safe function to move the throttle servo to a pre-determined position when the receiver detects interference.

4. Press the CLR button next to **MEMO** to the left of the display. This memorizes the current position of all channels that are set to F.S. - in this case the throttle which should be at idle. Whenever the RX detects interference it will move the throttle to this position. The remainder of the servos will hold their last good position.

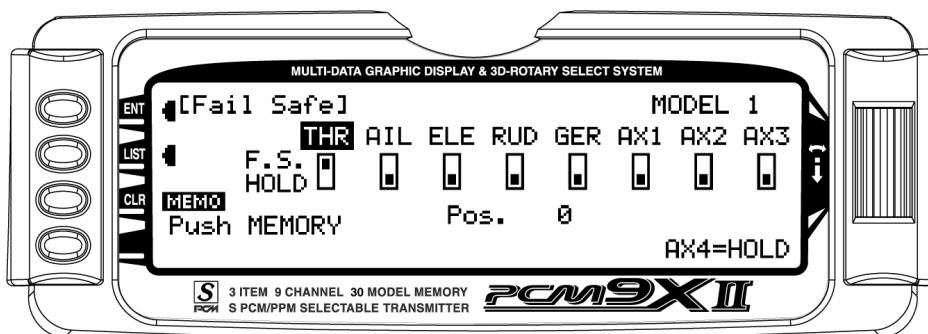

## Dual Rates and Exponential Curves

Dual Rates and Exponential curves can be very effective in setting up an aircraft to “feel” the way you would like it to feel when performing different types of maneuvers. You can essentially change the aircraft’s personality just by flipping a switch, causing the aircraft to take on traits that make certain maneuvers easier for the pilot. At times you may want the aircraft to feel very crisp, such as when performing point rolls and sided-loops and then feel softer for other maneuvers, such as rolling circles and consecutive rolls, and yet other times when you would like the aircraft to be very crisp but without a the tendency to be over-controlled, like in performing snap rolls. Dual Rates and Exponential curves can be combined to produce these traits for most any aircraft. When programming a Dual Rate and Exponential curve, always think about what kind of maneuver or flying style you plan to accomplish with it.

**Dual Rates (D/R)** limit how far a control surface travels. Without dual rates your control surfaces deflect to their full travel – the travel that you previously established with the TRVL ADJ. function and linkage setup. When a D/R is programmed, it limits the amount of deflection that occurs when the stick is moved to its extremes. For example, if you set an Elevator D/R to 75%, the Elevator will only deflect 75% or 3/4 of its full travel; if set to 50%, it will be limited to 1/2 of its full travel; and so forth. A D/R setting of 100% results in full travel again, as though there were no D/R programmed at all.

An example of programming a D/R for the Ailerons would be to set up an Aileron D/R for flying consecutive rolls by setting the Aileron D/R to 25% (actual percentage will vary). At this setting, moving the Aileron stick full left or full right would result in a roll rate of about 1 roll per second. This allows you to deflect the Aileron stick all the way and just hold it there while concentrating on Elevator and Rudder inputs – flying consecutive rolls just became easier.

**EXPONENTIAL (EXP)** does not limit the total deflection of a servo/control surface – the surface still moves 100% of its travel. It does, however, determine how the surface reaches its full travel, or how the control surface moves relative to the stick. When Exponential is not used, the servo response is said to be linear. That is, every movement of the stick causes the same movement in the servo--if the stick moves 20%, the servo moves 20% and the control surface follows the stick throughout the entire travel range. When plotted on a graph where the X-axis (left and right) = stick movement and the Y-axis (up and down) = servo

movement, the result is a straight line that is at 45 degrees.

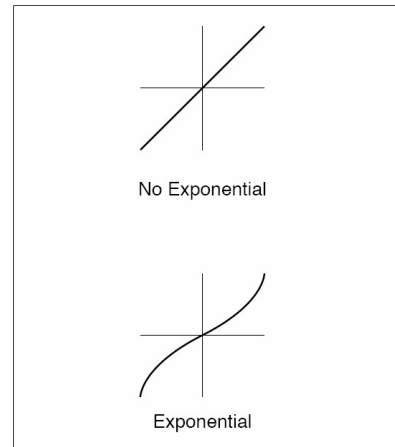

When using Exponential, a positive (+) exponential percentage causes the servo to move less when the stick is close to the neutral point, and to move more as the stick moves further from the neutral point. For instance, the stick is moved from neutral to 30% and the servo only moves from neutral to 10%. As the stick is moved further from center (from 30% to 50%), the servo moves further and faster (from 10% to 35%). The further the stick is moved away from center, the higher the rate of servo movement. The larger the positive (+) Exponential percentage, the further the stick must be moved from center before the servo rate increases, and the faster the servo rate becomes when it gets close to the end of its travel. When stick travel (left and right) versus servo travel (up and down) is plotted on a graph, the result is a “curve.” The curve stays close to the X-axis at the center (small servo movement) and moves away from the X-axis at a greater rate (more servo movement) as the stick is moved further off center.

Exponential is typically used to reduce sensitivity or otherwise dampen movements around the neutral stick position without sacrificing full servo travel. This provides the pilot with very smooth and precise control of the aircraft while allowing relatively large movements in the control stick. It becomes easier to make very smooth and precise corrections that are difficult to detect.

If negative exponential is used, it has the opposite effect. Servo travel is increased around center and slows towards the ends. Care must be taken with negative exponential, as an aircraft that is already overly sensitive may become uncontrollable with negative exponential. It can prove useful, however, when hovering a 3D type aircraft.

## Sub Trim Usage and Mechanical Advantage

### Sub Trim

Sub Trims are intended for relatively minor adjustments to servo linkages and not for major trim adjustments to the aircraft. Using excessive sub trim percentages can cause a loss in servo resolution, where the servo reaches its travel limit and stops moving before the control stick is fully deflected.

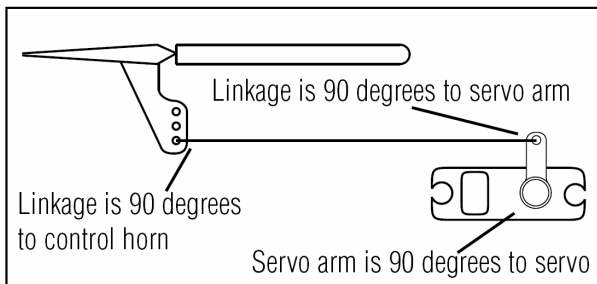

The diagram below illustrates an ideal servo/linkage setup when the servo is at neutral (no sub trim and digital trims centered). Notice that the servo arm is positioned at 90° or perpendicular to the servo. Also note that the linkage or rod is attached at 90° to both the servo arm and the control surface horn. This setup will result in the same amount of throw in both directions (0 differential throw). If the servo cannot be mounted parallel to the linkage/rod then just make sure the servo arm is at 90° to the control rod when the servo is at neutral.

### Mechanical Advantage

Mechanical Advantage is a very important concept when dealing with larger aircraft. It refers to the leverage that the servo can exert on the control surface. Since the control surfaces are rather large, it is important for the servo to have enough mechanical advantage or leverage to control them, regardless of the servo's rated torque. A large amount of torque is of little value if there is not enough leverage to use it. Insufficient leverage can lead to control surface flutter (usually a catastrophic event) and blow-back, where the air flow pushes the control surface backwards resulting in mushy or no control at higher speeds.

There are two ways to increase the mechanical advantage of the servo. One is to make sure that the control horn device, whether it be a horn as shown in the illustration above or a bolt with a Rocket City-type fastener, is long enough. The horn is the lever that the servo uses to control the surface. The longer the horn, the more leverage the servo has. It's like a Lug Wrench

– when you can't get a lug nut loose you put a piece of pipe over the end of the lug wrench to extend the handle and that gives you more leverage to break the lug nut free. It's the same thing—the lug nut is the control surface and you are the servo trying to move it. As a general rule-of-thumb, try to attach the linkage at the control surface so that it is at least 1" away from the surface – longer is better.

The second way to increase the mechanical advantage for the servo is to attach the linkage at the servo arm as far inward (towards the servo arm retaining screw) as possible while still providing enough throw. It's the "lever thing" again, but in reverse, as we are taking leverage away from the control surface by providing it with a shorter lever to work against the servo.

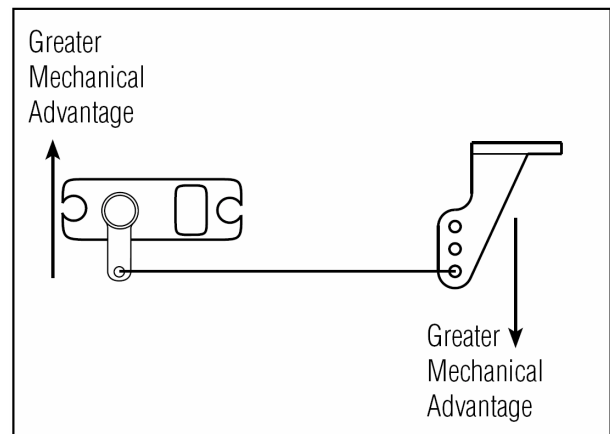

Ensure that the attach point is the same distance from the hinge line for like surfaces (two Ailerons, two Elevators and two Rudder horns). If the attach points are not the same distance from the hinge line there will be unequal throw and it will be more difficult to synchronize the surfaces for equal deflection. This is especially critical for the Rudder where two servos are attached to the same surface – unequal throw will cause the servos to fight one another causing excessive battery drain, and in severe cases may cause servo damage.

Always try to use the maximum amount of Travel (100%) that the radio provides. If it is too much travel, don't reduce the percentage of travel in the radio. Instead, move the linkage further away from the hinge line at the control surface and/or move the linkage inward on the servo arm or use a shorter arm. If you use high percentages of travel, you maintain resolution (fine movements of the stick result in fine positive movements of the control surface). When we decrease travel percentages, we lose resolution.

## Servo Precautions

---

- Do not lubricate servo gears or motors.
- Do not overload retract servos during retracted or extended conditions. Make sure they are able to travel their full deflection. Overloading or stalling a servo can cause excessive current drain.
- Make sure all servos move freely through their rotations and no linkages hang up or bind. A binding control linkage can cause a servo to draw excessive current. A stalled servo can drain a battery pack in a matter of minutes.
- Correct any control surface "buzz" or "flutter" as soon as it is noticed in flight, as this condition can destroy the feedback potentiometer in the servo. It may be extremely dangerous to ignore such "buzz" or "flutter."
- Use the supplied rubber grommets and brass servo eyelets when mounting your servos. Do not over-tighten the servo mounting screws, as this negates the dampening effect of the rubber grommets.
- Ensure the servo horn is securely fastened to the servo. Use only the JR® servo arm screws provided; the size is different from other manufacturers.
- Discontinue to use servo arms when they become "yellowed" or discolored. Such servo arms may be brittle and can snap at any time, possibly causing the aircraft to crash.
- Check all related mounting screws and linkages frequently. Aircraft often vibrate, causing linkages and screws to loosen.

## General notes

---

Radio controlled models are a great source of pleasure. Unfortunately, they can also pose a potential hazard if not operated and maintained properly.

It is imperative to install your radio control system correctly. Additionally, your level of piloting competency must be high enough to ensure that you are able to control your aircraft under all conditions. If you are a newcomer to radio controlled flying, please seek help from an experienced pilot or your local hobby shop.

### Safety Do's and Don'ts for Pilots

- Ensure your batteries have been properly charged prior to initial flight.
  - Keep track of the time the system is turned on so you will know how long you can safely operate your system.
  - Perform a ground range check prior to the initial flight of the day. See the "Daily Flight Checks Section" for information.
  - Check all control surfaces prior to each takeoff.
  - Use frequency flags.
- Do not fly your model near spectators, parking areas or any other area that could result in injury to people or damage of property.
  - Do not fly during adverse weather conditions. Poor visibility can cause disorientation and loss of control of your aircraft. Strong winds can cause similar problems.
  - Do not fly unless your frequency is clear.
- Warning:** Only one transmitter at a time can operate on a given frequency. If you turn on your transmitter while someone else is operating a model on your frequency, both pilots will lose control of their models. Only one person can use a given frequency at a time. It does not matter if it is AM, FM or PCM—only one frequency at a time.
- Do not point the transmitter antenna directly toward the model. The radiation pattern from the tip of the antenna is inherently low.
  - Do not take chances. If at any time during flight you observe any erratic or abnormal operation, and immediately and do not resume flight until the cause of the problem has been ascertained and corrected. Safety can never be taken lightly.

# Aviation Regulations

---

## 1. Purpose

This advisory outlines safety standards for operations of model aircraft. We encourage voluntary compliance with these standards.

## 2. Background

Attention has been drawn to the increase in model aircraft operation. There is a need for added caution when operating free flight and radio controlled craft in order to avoid creating a noise nuisance or a potential hazard to full-scale aircraft and persons and/or property on the surface.

## 3. Operating Standards

Modelers generally are concerned with safety and exercise good judgment when flying model aircraft. However, in the interest of safer skies, we encourage operators of radio controlled and free flight models to comply with the following standards:

- a. Exercise vigilance in locating full-scale aircraft (get help if possible) so as not to create a collision hazard.
- b. Select an operating site at sufficient distance from populated areas so you do not create a noise problem or a potential hazard.
- c. Do not fly higher than 300 feet above the surface.
- d. Always operate more than three kilometers from the boundary of an airport unless you are given permission to be closer by the appropriate air traffic control facility in the case of an airport for which a control zone has been designated or by the airport manager in the case of other airports.
- e. Do not hesitate to ask for assistance in complying with these guidelines at the airport traffic control tower or air route traffic control center nearest the site of your proposed operation.

## Daily Flight Checks

---

1. Check the battery voltage on both the transmitter and the receiver battery packs. Do not fly below 9.0V on the transmitter or below 4.7V on the receiver. To do so can crash your aircraft.

**Note:** When you check these batteries, ensure that you have the polarities correct on your expanded scale voltmeter.

2. Check all hardware (linkages, screws, nuts, and bolts) prior to each day's flight. Be sure that binding does not occur and that all parts are properly secured.

3. Ensure that all surfaces are moving in the proper manner.

4. Perform a ground range check before each day's flying session. The range check should be as follows:

- Do not extend the transmitter antenna at this time. Turn the transmitter "on."

- Turn the model "on."
- Slowly walk away from the model while moving the control surfaces. The aircraft should function properly at a distance of 60–75 feet.
- For PCM Only: With the throttle fail safe preset to idle, bring the throttle slightly above idle. Walk away until the throttle drops to idle. This will be the distance of the range check.

5. Prior to starting your aircraft, turn off your transmitter, then turn it back on. Do this each time you start your aircraft. If any critical switches are on without your knowledge, the transmitter alarm will warn you at this time.

6. Check that all trim levers are in the proper location.

7. All servo pigtailed and switch harness plugs should be secured in the receiver. Make sure that the switch harness moves freely in both directions.

## Warranty Information

---

**Important:** Be sure to keep your original dated sales receipt, as you will be required to provide proof-of-purchase date for the equipment to be serviced under warranty.

### Warranty Coverage

Your new JR® Remote Control Radio System is warranted to the original purchaser against manufacturer defects in material and workmanship for 1 year from the date of purchase. During this period, the JR Service Center will repair or replace, at our discretion, any component that is found to be factory defective at no cost to the purchaser. This warranty is limited to the original purchaser of the unit and is not transferable.

This warranty does not apply to any unit that has been improperly installed, mishandled, abused or damaged in a crash, or to any unit that has been repaired or altered by any unauthorized agencies. Under no circumstances will the buyer be entitled to consequential or incidental damages. This limited warranty gives you specific legal rights; you also have other rights, which may vary from state to state. As with all fine electronic equipment, do not subject your radio system to extreme temperatures, humidity or moisture. Do not leave it in direct sunlight for long periods of time.

### Repair Service Directions

In the event that your JR radio needs service, please follow the instructions listed below.

1. Check all on/off switches to be sure they are off. This will speed the repair process of checking battery condition.
2. Return your system components only (transmitter, receiver, servos, etc.). Do not return your system installed in a model aircraft, car, boat, etc.

3. Preferably, use the original carton/packaging (molded foam container), or equivalent, to ship your system. Do not use the system carton itself as a shipping carton, you should package the system carton within a sturdy shipping container using additional packing material to safeguard against damage during transit. Include complete name and address information inside the carton, as well as clearly writing it on the outer label/return address area.

4. Include detailed information explaining your operation of the system and problem(s) encountered. Provide an itemized list of equipment enclosed and identify any particular area/function, which may better assist our technicians in addressing your concerns. Date your correspondence, and be sure your complete name and address appear on this enclosure.

5. Include your name, mailing address, and a phone number where you can be reached during the business day.

### Warranty Repairs

To receive warranty service, you must include a copy of your original dated sales receipt to verify your proof-of-purchase date. Providing that warranty conditions have been met, your radio will be repaired without charge.

### Normal Non-Warranty Repairs

Should your repair cost exceed 50% of the retail purchase cost, you will be provided with an estimate advising you of your options.

Mail your system to:  
Your local store