

ERGO 30 CC PM

ASSEMBLY INSTRUCTIONS



ERGO SPECIFICATIONS

Overall Length	40.5"	Tail Rotor Diameter	9.17"
Overall Height	15.9"	Gear Ratio	9.78:1 : 5.18
Main Rotor Diameter	48.5"	Gross Weight	6.75-7.0 lbs.

INDEX

Section	Description	Page	Section	Description	Page
	Introduction	3	6-1	Servo Installation	29
	Ergo 30SS	4	6-2	Tail Control Rod Assembly	30
	Additional Items Required to Complete the JR Ergo	4-6	6-3	Tail Control Rod Installation	30
	Hardware Identification	7	6-4	Gyro/Receiver/Switch Harness/Battery Installation	31
1-1	Clutch Bell/Start Shaft Assembly	8		Understanding Swashplate Control Systems	32-33
1-2	Tail Drive Pinion/Bearing Block Assembly	8		How JR 120 CCPM Works	34
1-3	Elevator Arm Assembly	9		Radio System Requirements	34
1-4	Fuel Tank Assembly	9		CCPM Software Activation and Initial Adjustment	35-37
2-1	Upper Main Frame Section Assembly	10		Important CCPM Programming Dos and Don'ts	38
2-2	Upper Main Frame Clutch/Tail Pinion Installation	11	7-1	Servo Arm Preparation and Installation	39
2-3	Lower Main Frame Assembly/Fuel Tank Installation	12	7-2	CCPM Servo Centering with the Sub-Trim Function	40
2-4	Upper/Lower Main Frame Assembly Attachment	13	7-3	CCPM Linkage Connections	41
2-5	Cooling Fan Shroud Installation	14	7-4	Checking the Swashplate for Level	42
2-6	Front Radio Tray and Gyro Mount Installation	14	7-5	Pitch-to-Aileron Mixing Adjustment w/Travel Adjust	43
3-1	Main Drive Gear/Autorotation Assembly	15	7-6	Pitch-to-Elevator Mixing Adjustment w/Travel Adjust	44
3-2	Main Drive Gear/Autorotation Assembly Installation	15	7-7	Tail Control Rod Servo Connection	45
3-3	.32-.38 Cooling Fan/Hub Installation	16	7-8	Throttle Linkage Installation	46
3-4	.32-.38 Engine Mount Attachment	16	8-1	Body Assembly/Canopy Attachment	47
3-5	Clutch Assembly Attachment	17	8-2	Body Attachment	47
3-6	Engine Installation	17	8-3	Main Rotor Blade Balancing	49
3-7	Installation of the Muffler	18	8-4	Main Rotor Blade Attachment	49
3-8	Landing Gear Assembly Installation	18		Final Servo Adjustment and Radio Set-Up	50-52
4-1	Rotor Head Hub Assembly	19		Final Pre-Flight Check	53
4-2	Main Blade Holder Assembly	19		General Maintenance	54
4-3	Main Blade Holder/Seesaw Attachment	20		Data Sheets	55-60
4-4	Seesaw Mixing Arm Installation	20		Rotor Head Assembly	61
4-5	Swashplate Adjustment	21		Rotor Head Assembly Parts List	62
4-6	Swashplate/Washout Assembly Installation	21		Start Shaft/Clutch/Engine Assembly	63
4-7	Rotor Head Installation	22		Start Shaft/Clutch/Engine Assembly Parts List	64
4-8	Flybar Installation	22		Washout Unit/CCPM Control System Assembly	65
4-9	Flybar Paddle Attachment	23		Washout Unit/CCPM Control System Parts	66
4-10	Rotor Head/Swashplate Control Rod Installation	23		Upper Main Frame/Body Set/Main Gear Assembly	67
5-1	Tail Output Shaft/Pulley Assembly	24		Upper Main Frame/Body Set/Main Gear Assembly Parts List	68
5-2	Tail Gear Case Assembly	25		Lower Main Frame/Landing Gear/Fuel Tank Assembly	69
5-3	Tail Center Hub Assembly	24		Lower Main Frame/Landing Gear/Fuel Tank Parts List	70
5-4	Tail Blade Holder Assembly	25		Tail Boom/Tail Brace/Tail Boom Carrier Assembly	71
5-5	Tail Pitch Control Lever Installation	26		Tail Boom/Tail Brace/Tail Boom Carrier Parts List	72
5-6	Tail Fin Attachment	26		Tail Rotor Assembly	73
5-7	Tail Boom Carrier Installation	27		Tail Rotor Assembly Parts List	74
5-8	Tail Boom Assembly Installation	27			
5-9	Tail Boom Brace Assembly	28			
5-10	Tail Boom Brace Installation	28			

Ergo 30 CCPM

INTRODUCTION

Congratulations on your purchase of the JR Ergo 30SS CCPM helicopter kit.

This kit has been both engineered and manufactured by JR with help from some of Japan's top R/C helicopter engineers now employed by JR.

As you may well know, for years the name JR has been synonymous with state-of-the-art, high quality radio control systems known the world over for their exceptional reliability and engineering.

JR now brings this reputation and knowledge into the helicopter market with the development of the Ergo and the organization of the JR heli division. Years in the making, the Ergo's superior quality and exceptional parts fit and finish create a new standard of quality that was previously unavailable.

JR CCPM

To take the Ergo design to the next level, JR's designers turned to CCPM (Cyclic/Collective Pitch Mixing). CCPM is a unique control system that mounts 3 servos below the swashplate with short, straight linkages directly to the swashplate at 120 degree intervals. With CCPM, complex collective and cyclic mixing is accomplished electronically, rather than mechanically. As a result, many parts are eliminated, along with excessive control system play, not to mention quicker building and lower maintenance.

What's more, you get more servo power from CCPM. That's because instead of one servo moving the collective, you now have three. Instead of one servo moving the cyclic, you have two.

Before you begin the assembly of your Ergo CCPM, we suggest that you first review the entire instruction manual to become familiar with the assembly sequences and parts layout.

Warning

The radio controlled model helicopter contained in this kit is not a toy, but a sophisticated piece of equipment. This product is not recommended for use by children. Radio controlled models such as this are capable of causing both property damage and/or bodily harm to both the operator/assembler and/or spectator if not properly assembled and operated. Horizon Hobby Distributors assumes no liability for damage that could occur from the assembly and/or use/misuse of this product.

AMA Information

We strongly encourage all prospective and current R/C aircraft pilots to join the Academy of Model Aeronautics. The AMA is a non-profit organization that provides services to model aircraft pilots. As an AMA member you will receive a monthly

magazine entitled Model Aviation, as well as a liability insurance plan to cover against possible accident or injury. All AMA charter aircraft clubs require individuals to hold a current AMA sporting license prior to operation of their models. For further information, you can contact the AMA at:

Academy of Model Aeronautics
5151 East Memorial Drive
Muncie, IN 47302
(317) 287-1256

Pre-Assembly Information

When first opening your Ergo kit, you will notice that all of the parts are packaged and numbered to coordinate with the assembly step numbers of this instruction manual.

All small hardware (nuts, bolts, washers, etc.) for each step are separated and packaged separately within the main parts bags. When beginning a section, you will need to open only the bag with the corresponding number to the section you are about to start. It is suggested that you place all of the hardware in an open container (e.g., coffee can) during assembly so as not to lose any of the small parts. It may also be helpful to familiarize yourself with the various sizes of screws, bolts, nuts, etc., as illustrated in the appropriate assembly section before you begin assembly. In most cases, at the end of each assembly section there should be no parts remaining.

Great care has been taken in filling the bags with the correct quantity of parts and hardware for each section. However, occasionally mistakes do happen. In the event that you find a parts shortage or are in need of technical assistance, please contact your local JR heli division parts dealer, or contact the Horizon Service Center directly.

Horizon Service Center
4105 Fieldstone Road
Champaign, IL 61822
(217) 355-9511 (9am to 5pm CST)

ERGO 30SS FEATURES

CCPM (Cyclic/Collective Pitch Mixing):

More Accurate: Control system play is greatly reduced.

Simpler: Fewer links to set-up and maintain.

More Powerful: Collective has three times the servo power, cyclic has double.

Heavy-Duty Aluminum Quad Frame System

Provides excellent rigidity and vibration absorption.

One-Way Hex Start Shaft System

Provides positive starting. Starter shaft utilizes a one-way bearing that allows the shaft to stop after the engine is started.

Wide Spread Tail Output Shaft Bearings

Reduces vibration and improves control response.

Belt-Driven Tail Rotor Design

Provides easy adjustment and low maintenance. Also eliminates the need for optional/expensive tube drive shafts.

Precision Ball Bearings at All Critical Locations

Provide low wear, high precision and reduced maintenance.

Semi Scale (SS) Design

Durable polyethylene Schweizer 300 body for scale-like appearance, while retaining a rugged, serviceable design.

Self-Aligning One-Piece Steel Clutch System

Offers easy installation and adjustment with exceptional reliability.

Straight Blade Axle Rotor Head Design

Provides high responsiveness and solid blade tracking.

Low Drag Flybar Paddles

Provide quick yet smooth cyclic response at all flight speeds.

Heavy-Duty Tail Boom Carrier

Provides increased structural rigidity and improved tail rotor precision.

Pre-Finished Main Rotor Blades

Provide easy assembly with excellent flight characteristics.

Superior Parts Fit and Finish

Make assembly trouble free and enjoyable.

ADDITIONAL ITEMS REQUIRED TO COMPLETE THE JR ERGO

1. RADIO SYSTEM REQUIREMENTS (NOT INCLUDED):

6-channel or greater R/C helicopter system with 120° CCPM function (see list below), 5 servos, 1000 mAh receiver battery and gyro.

CCPM-Ready JR Radio Systems

Most current JR Heli radio systems (XP652, XP8103 w/digital trims, 10X, as well as older 10 series systems) are equipped with 120° CCPM electronics for use with the Ergo CCPM machines. Radios you may be flying now, like the X347, X388S, XP783, and XP8103* have CCPM capability built in, but require activation by the Horizon Service Department.

Please call (217) 355-9511 for details.

* Please note that many XP8103 systems have the CCPM function already activated. Please check with the Horizon Service Center for details.

CURRENT RADIO SYSTEMS

JRP1656** PCM 10X, 5-8231 Servos (50/53/72 MHz)
JRP165TX PCM 10X, Transmitter Only (50/53/72 MHz)
JRP8622** XP8103FM, 5-517 Servos (50/53/72 MHz)
JRP8653** XP8103PCM, 5-531 Servos (50/53/72 MHz)
JRP6622** XP652 FM, 5-517 Servos (50/53/72 MHz)



JR XP652



JR 10X



JR XP8103 DT



5 servos, 1100mAh battery, 6 channel receiver & accessories



450 Piezo Gyro



12" Aileron Extensions (2)

2. ENGINE REQUIREMENTS (NOT INCLUDED):

A .32-.38 R/C helicopter engine



(MDS .38 Heli Engine Shown)



(Webra 35 Heli Engine Shown)

A special helicopter type muffler is also required



(JRP960078 Ergo .32-.36 Muffler Shown)



(KSJ399 Muffler Shown)

3. BUILDING SUPPLIES (NOT INCLUDED):

The following items are needed to complete the assembly of the JR Ergo:



Fuel Filter



Silicone Fuel Tubing



Whip Antenna



Glow Plugs



Double Sided Servo Mounting Tape



Threadlock
(Blue and Red Required)



Nylon Wire Ties To
Secure Radio Wires



Heavy-Duty Servo
Arms w/Screws
(JRPA215)

4. TOOLS NEEDED TO ASSEMBLE THE JR ERGO (NOT INCLUDED):



Phillips Screwdriver



Nut Drivers: 5mm, 7mm



Needle Nose Pliers



Scissors



Drill and Drill Bits



Small Hammer



X-Acto Knife



Metric Ruler



Ball Link Pliers



Ball Link Sizing Tool

5. FIELD EQUIPMENT REQUIRED (NOT INCLUDED):



12 Volt Electric Starter



12 Volt Starting Battery



1.5 Volt Glow Plug Battery

or



Remote Glow Plug Adaptor



Helicopter Fuel, 15% - 30%



Fuel Pump



Hex Starting Shaft



Pitch Gauge



Training Gear (Beginners Only)

HARDWARE IDENTIFICATION

There are many various sizes and shapes of hardware included in this kit. Prior to assembly, please be careful to identify each screw by matching it to the full size screw outlines included in each step.

All of the hardware, screws, nuts, etc., contained in the Ergo kit are described in the following A, B, C manner:

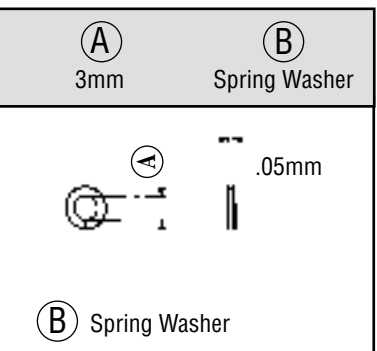
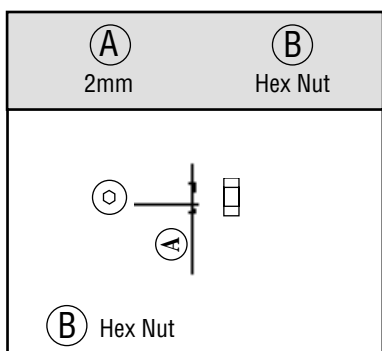
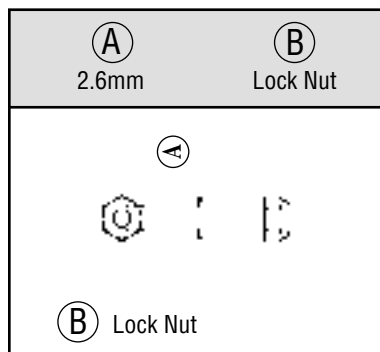
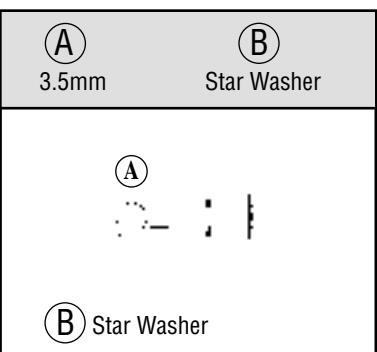
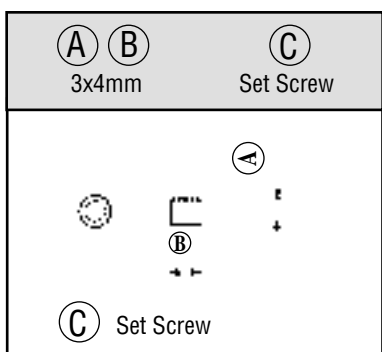
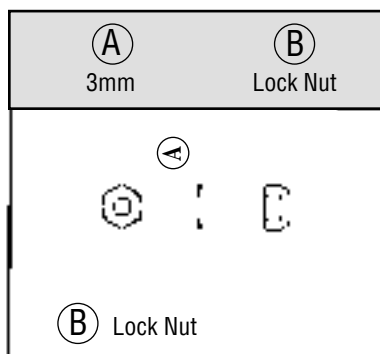
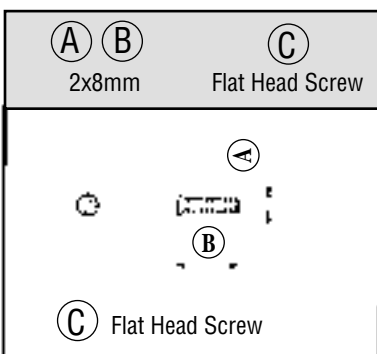
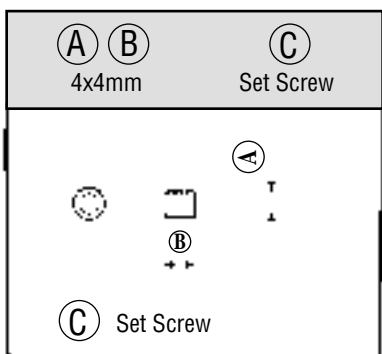
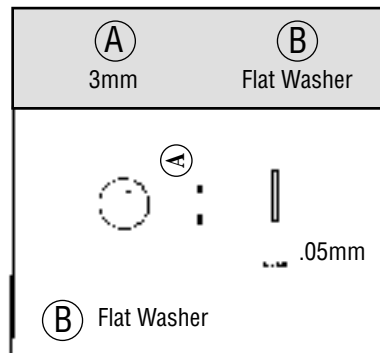
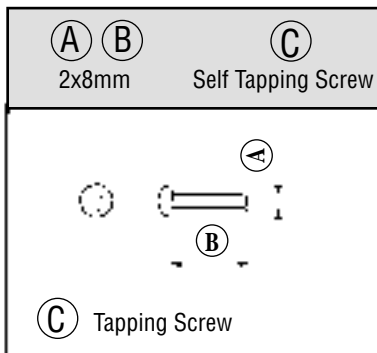
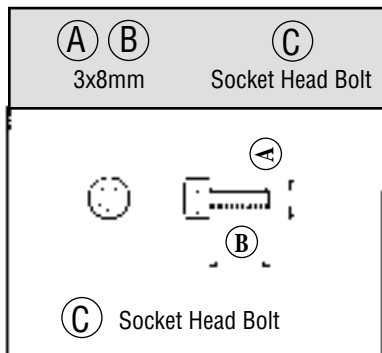

1-1

CLUTCH BELL/START SHAFT ASSEMBLY

 1 pc
3x4mm Set Screw

 Use Blue & Red Threadlock

* When installing the Start Shaft Bearing Block Assembly, be sure the Bearing Block is positioned so the small inside diameter bearing faces upward toward the starter hex adaptor, with the large inside diameter bearing toward the Clutchbell Assembly.

Use Blue Threadlock

3x4mm Set Screw

*Start Shaft Bearing Block with ball bearing

Apply a very light coat of Red Threadlock before inserting pinion gear into the start shaft bearing block

Clutch Bell Assembly

Starter Hex Adaptor

Complete Assembly

Start Shaft

Note: Be sure to allow a slight amount of clearance between the Start Hex Adaptor and the Bearing Block to prevent binding.

1-2

TAIL DRIVE PINION/BEARING BLOCK ASSEMBLY

 Use Red Threadlock

  ...1 pc
3x6mm Socket Head Bolt

 1 pc
3mm Flat Washer

Tail Drive Pinion Bearing Block

Install the Upper Bearing Block so that the bearing is toward the bottom:

UP



Tail Drive Pinion with Shaft

Tail Drive Pinion Bearing Block

Front Tail Belt Pulley (Install Flat Side Down)

3mm Flat Washer

3x6mm Socket Head Bolt

Use Red Threadlock



Complete Assembly





Install the Lower Bearing Block so the bearing face is toward the top:

UP



1-3

ELEVATOR ARM ASSEMBLY

- 1 pc
- 3mm Lock Nut
- 1 pc
- 11mm Long Ball Arm
- 1 pc
- Elevator Arm Pin
- 1 pc
- 3mm Flat Washer

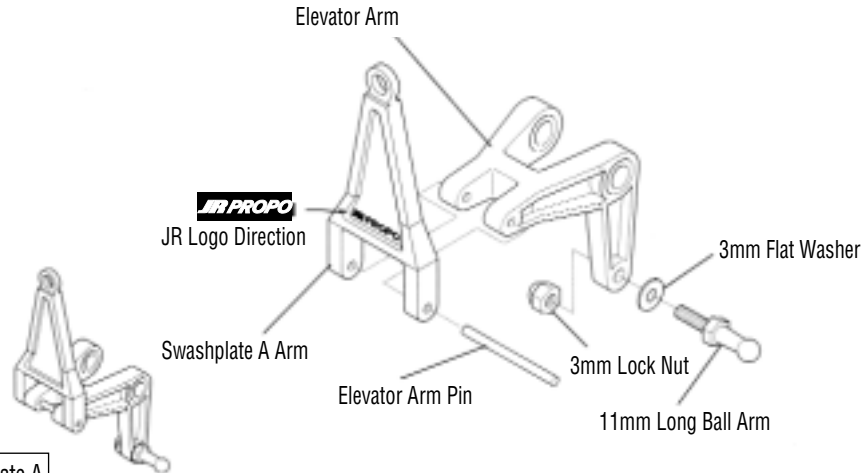

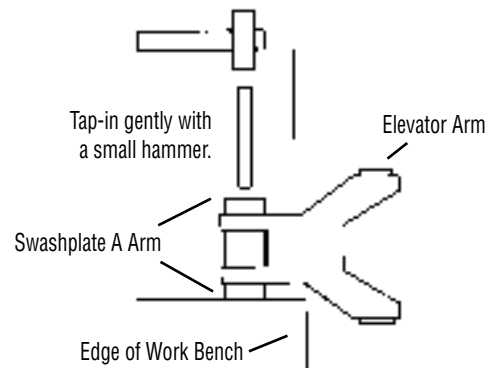
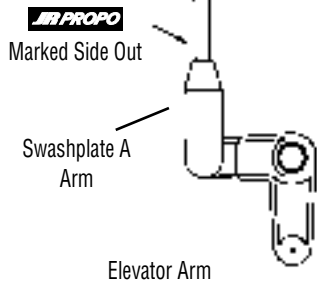

Caution: Be sure to note the correct Swashplate A Arm installation direction.



1-4

FUEL TANK ASSEMBLY

- 1 pc
- 7mm Hex Nut
- 1 pc
- 7x12x1mm Washer

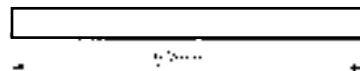

* Trim before installation to a length of 57mm

Silicone Fuel Tubing (not included)
Connects to Muffler Pressure Tap

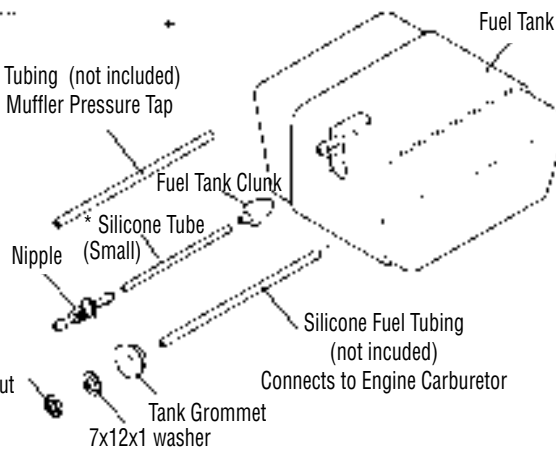

1. Cut the small Silicone Fuel Tubing (included) to a length of 57mm. Next, connect the Fuel Tank Clunk, Nipple, and medium Silicone Fuel Tubing (not included) as shown at right.

2. Insert the assembly (Fuel Tank Clunk first) into the Fuel Tank opening so the Nipple is inside the tank. Next, slide the Fuel Tank Grommet over the medium Fuel Tubing.

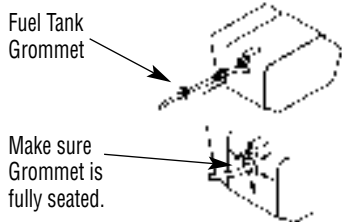

3. Insert the Fuel Tank Grommet into the Fuel Tank opening, making sure it's fully seated.

Pull out until Nipple threads are exposed

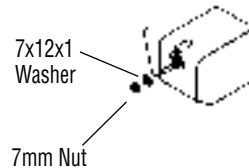

4. Pull the medium Fuel Tubing out of the Fuel Tank until the threads of the Fuel Tank Nipple are exposed.

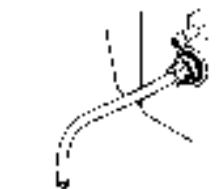

5. Remove the medium Silicone Fuel Tubing from the Nipple and secure the Nipple to the Fuel Tank using the 7x12x1mm Washer and 7mm Nut supplied. Be sure to secure this assembly to avoid leakage.



After assembly, check to be sure the Fuel Tank Clunk can move from the bottom to the top of the tank without touching the back wall of the Fuel Tank.

2-2

UPPER MAIN FRAME CLUTCH/TAIL PINION INSTALLATION



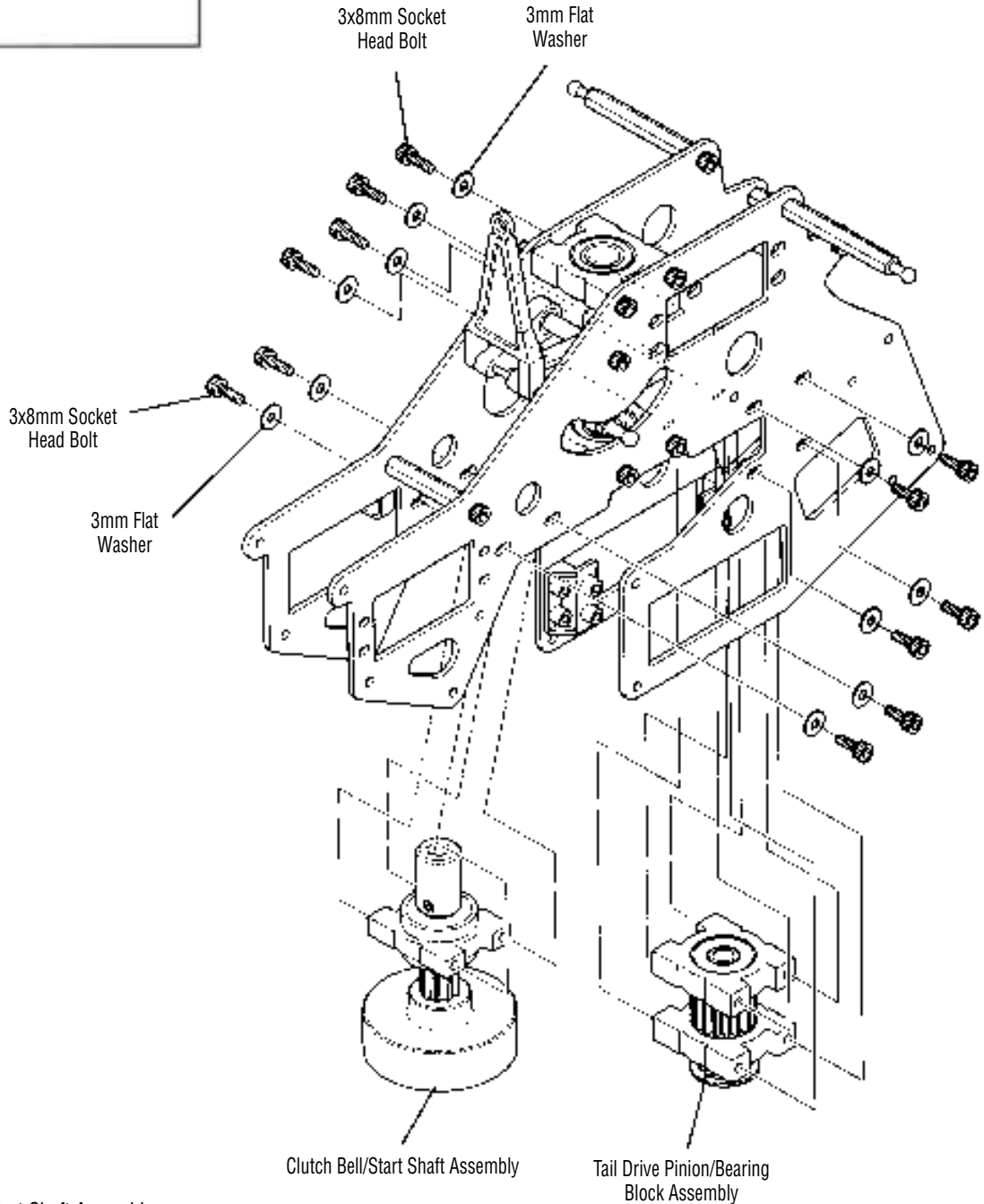



 12 pcs
3x8mm Socket Head Bolt	
 12 pcs
3mm Flat Washer	



Note: Both the Clutch Bell/Start Shaft Assembly (Step 1-1) and the Tail Drive Pinion/Bearing Block Assembly (Step 1-2) are temporarily installed at this time. These assemblies will be adjusted and secured in Step 3-2.

2-3

LOWER MAIN FRAME ASSEMBLY/FUEL TANK INSTALLATION

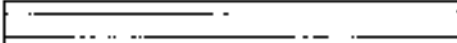
	 8 pcs
3x8mm Socket Head Bolt		
	 2 pcs
3x10mm Socket Head Bolt		
	6 pcs
3mm Lock Nut		
	2 pcs
Main Frame Standoff, 60mm		



Use Blue Locktite

Note: Install the Fuel Tank and Tank Mounting Rubber into the lower frame halves before attaching the Main Frame Standoffs.

When securing the Standoffs to the frame, position the bottoms of the level surface to prevent twisting during tightening.

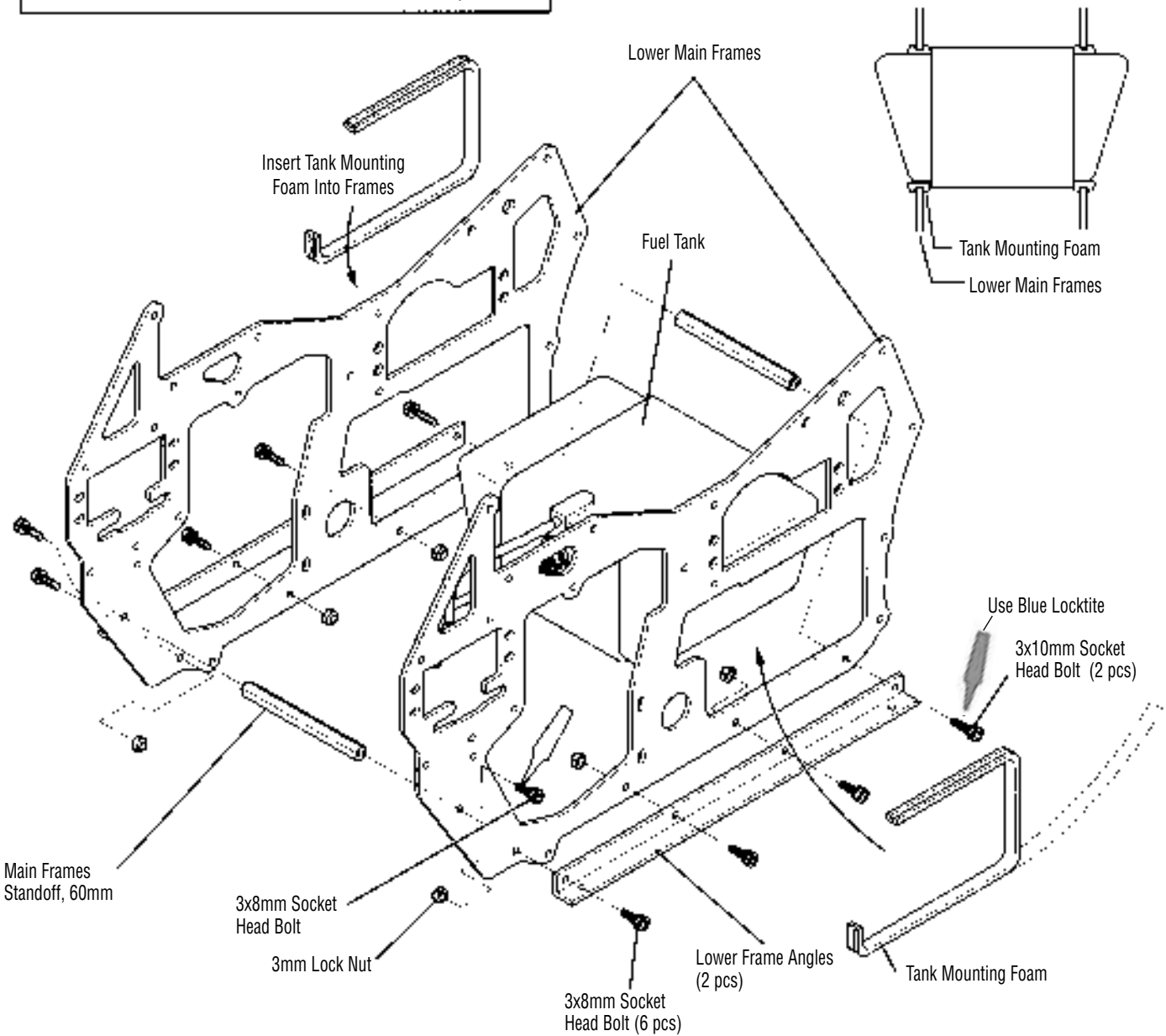

2-4

UPPER/LOWER MAIN FRAME ASSEMBLY ATTACHMENT

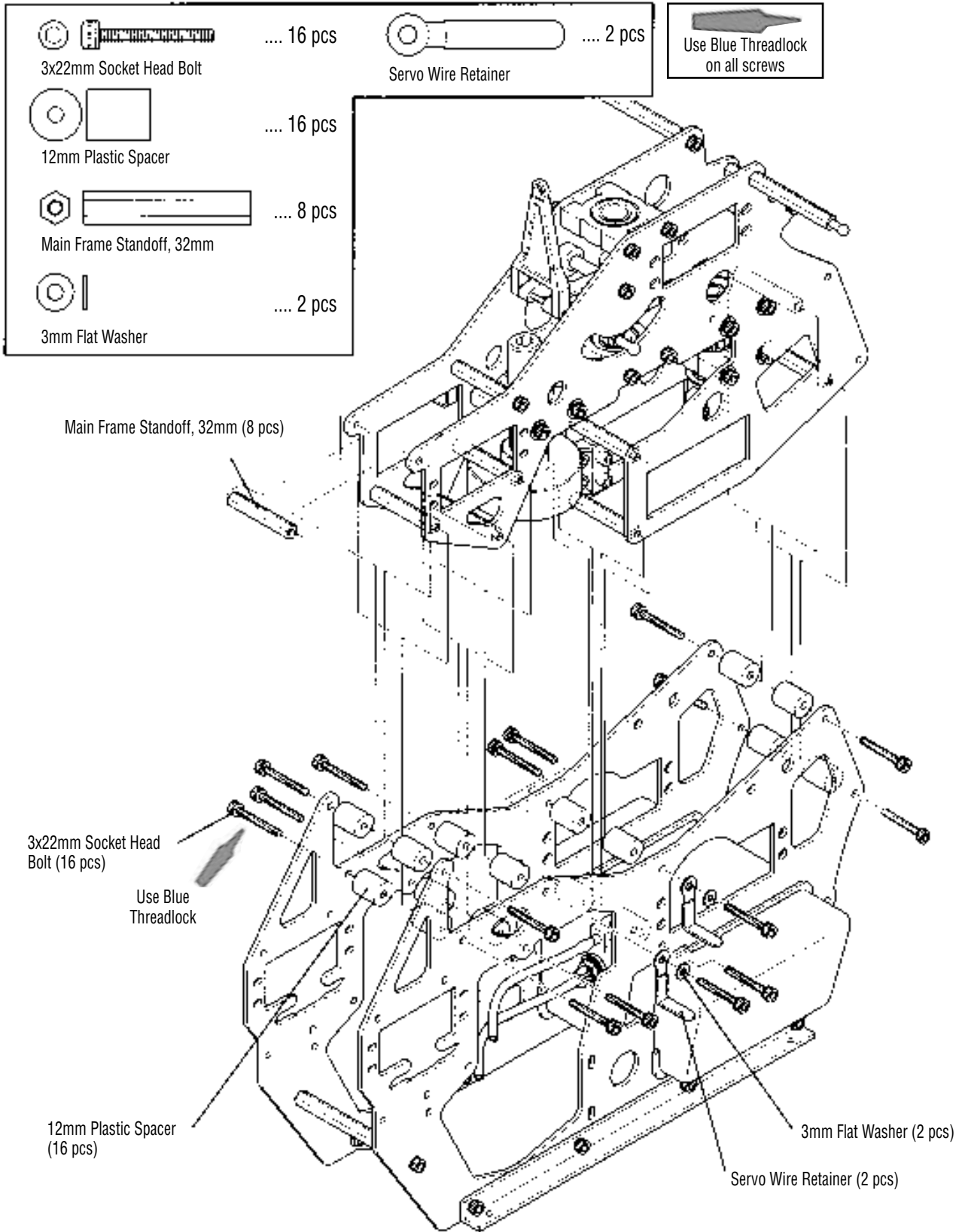

2-5

COOLING FAN SHROUD INSTALLATION

4 pcs
2.6x8mm Self Tapping Screw

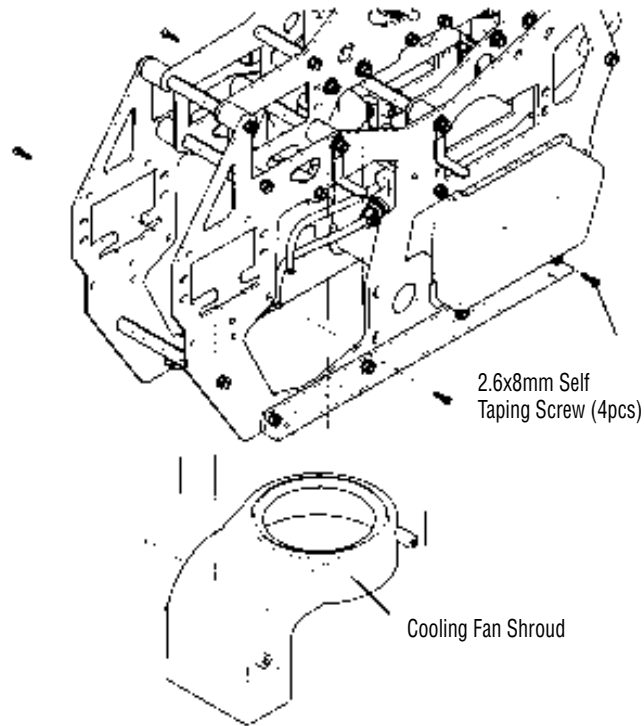

2-6

FRONT RADIO TRAY AND GYRO MOUNT INSTALLATION

6 pcs
3x10mm Socket Head Bolt

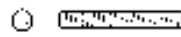
2 pcs
3x18mm Set Screw

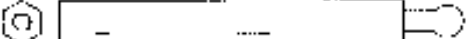
2 pcs
Body Mounting Standoff, 50mm

Use Blue Locktite

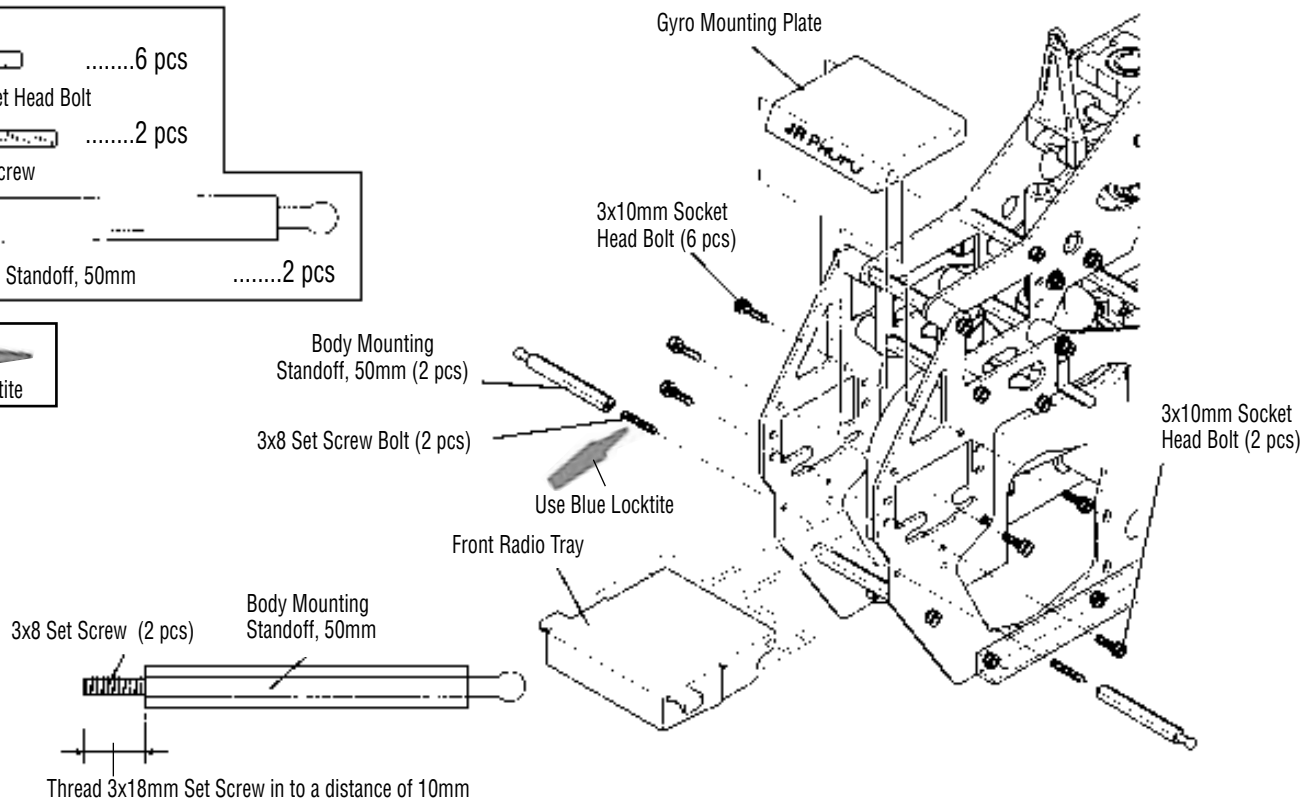

3-1

MAIN DRIVE GEAR/AUTOROTATION ASSEMBLY

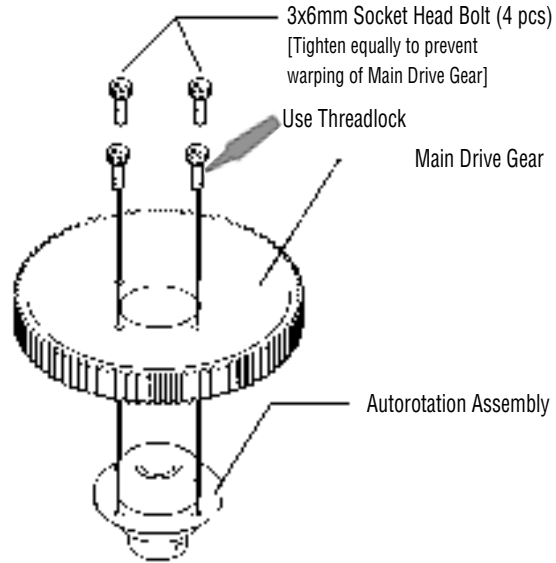

3-2

MAIN DRIVE GEAR/AUTOROTATION ASSEMBLY INSTALLATION

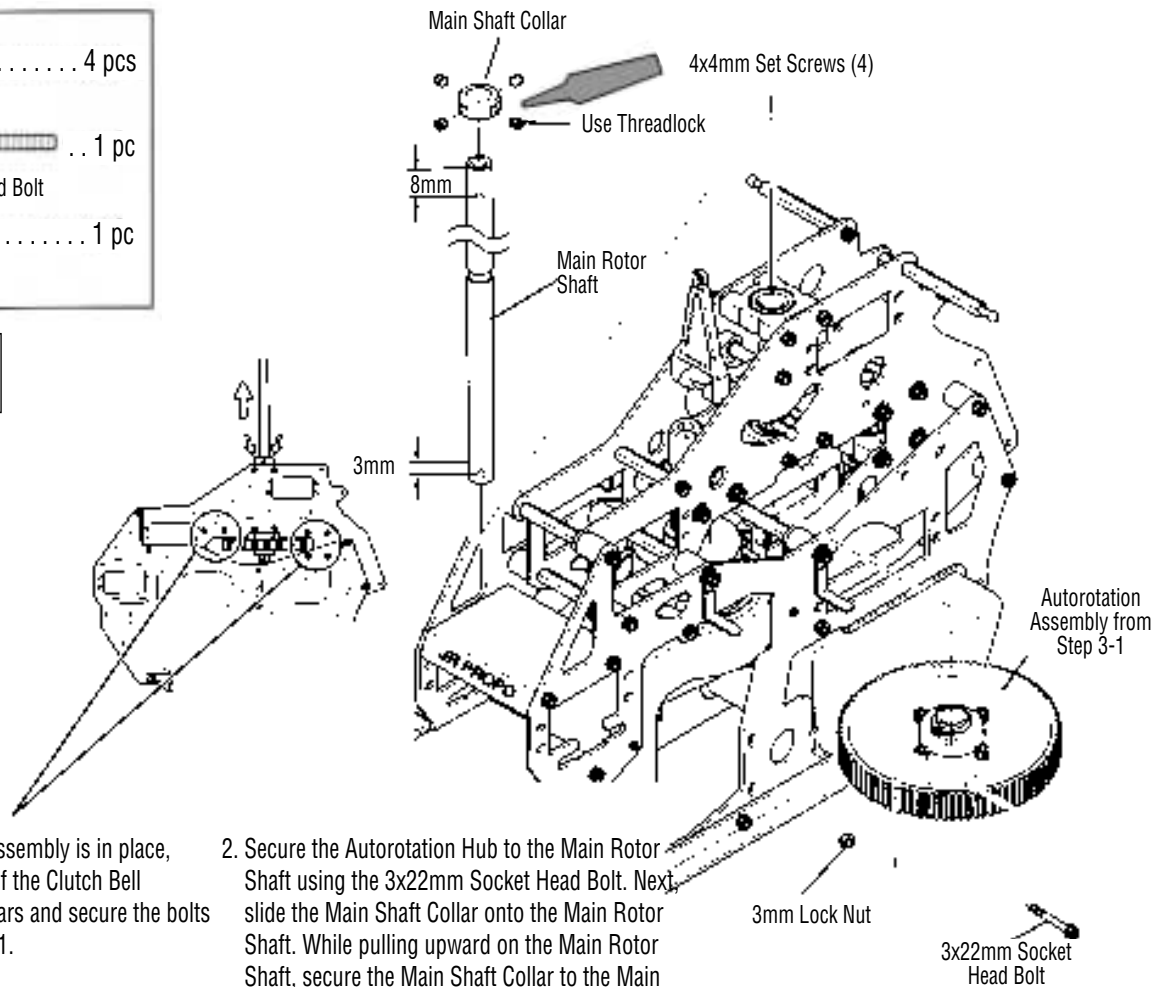
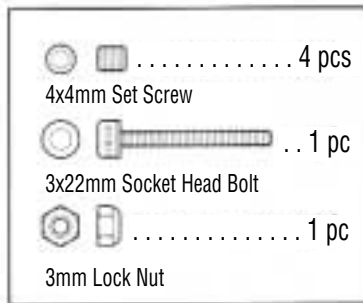

1. Once the Main Shaft Assembly is in place, adjust the gear mesh of the Clutch Bell and Tail Belt Pinion Gears and secure the bolts left loose from Step 2-1.

2. Secure the Autorotation Hub to the Main Rotor Shaft using the 3x22mm Socket Head Bolt. Next, slide the Main Shaft Collar onto the Main Rotor Shaft. While pulling upward on the Main Rotor Shaft, secure the Main Shaft Collar to the Main Rotor Shaft using the four 4x4mm Set Screws.

3-3

.32-.38 COOLING FAN/HUB INSTALLATION

For proper installation of the fan assembly, it's necessary for the engine to have the prop drive washer installed.

O.S. .32SX-H Installation

For proper installation of this engine, it will be necessary to purchase the O.S. Prop Drive Washer for this engine (Part #23408000).

*It is recommended that a Piston Locking Tool be used to properly secure the Fan Assembly to the engine.

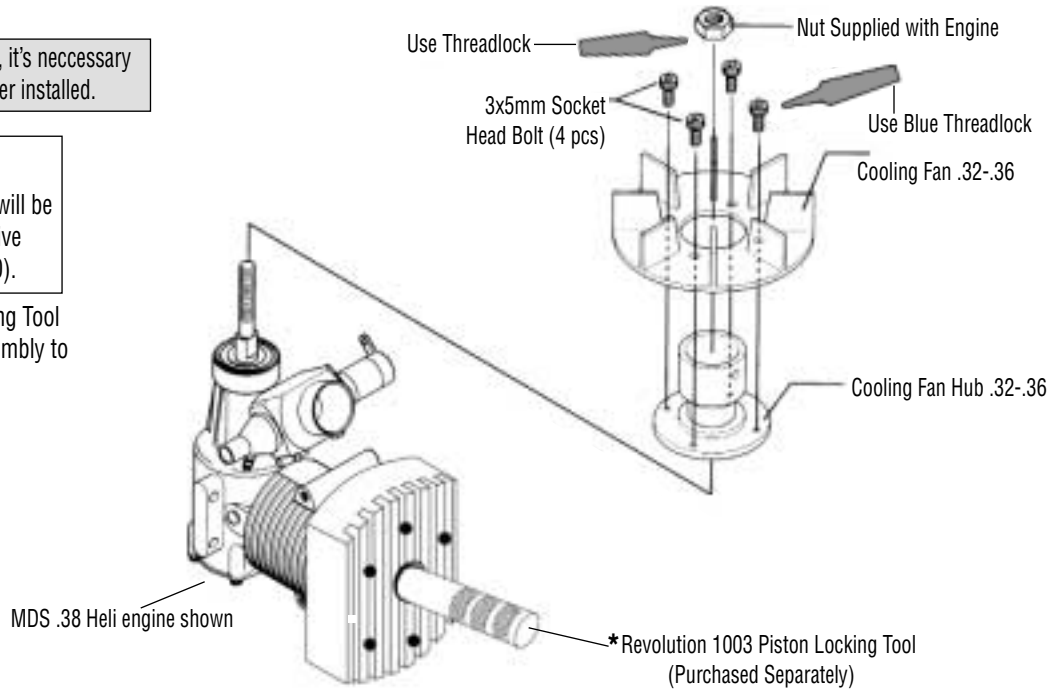

3-4

.32-.38 ENGINE MOUNT ATTACHMENT

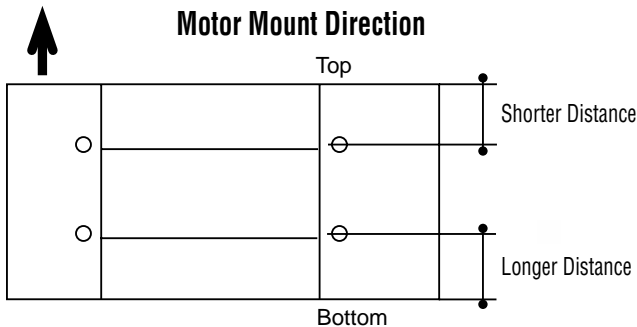
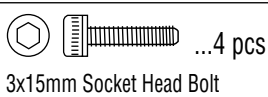

It is important to note the proper direction for the motor mount installation for achieving the correct alignment of the engine.

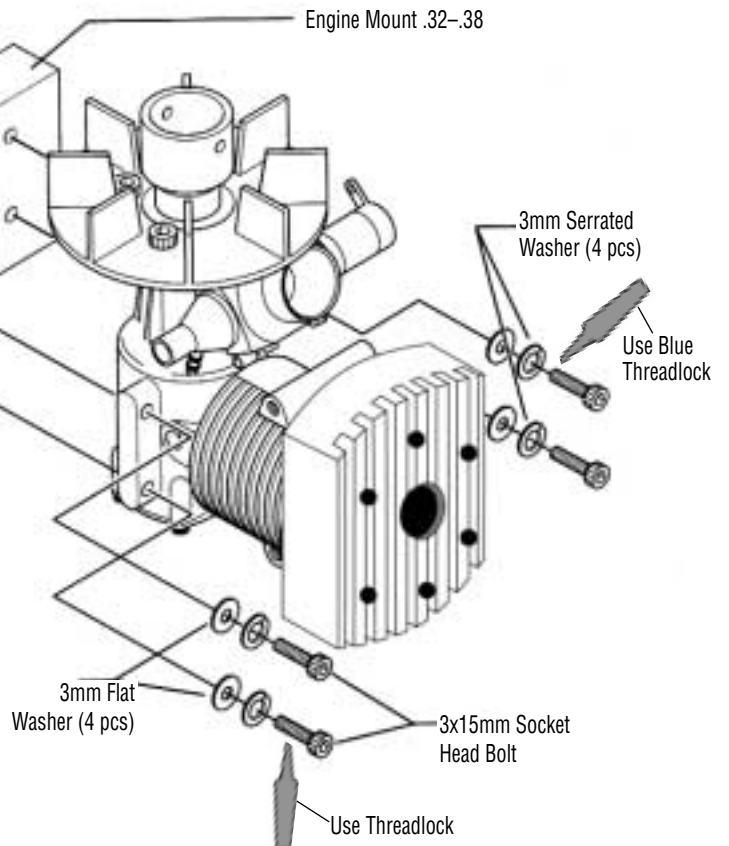

3-5

CLUTCH ASSEMBLY ATTACHMENT

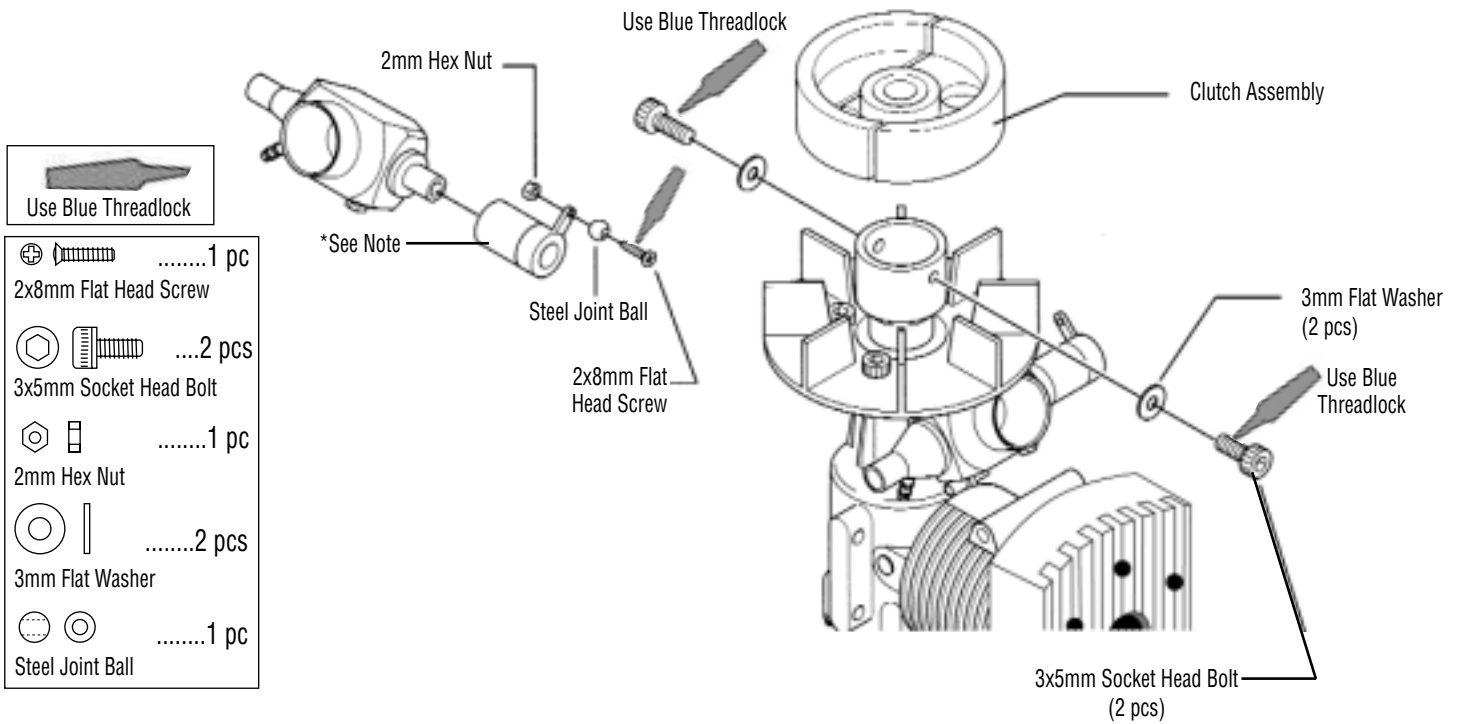

3-6

ENGINE INSTALLATION

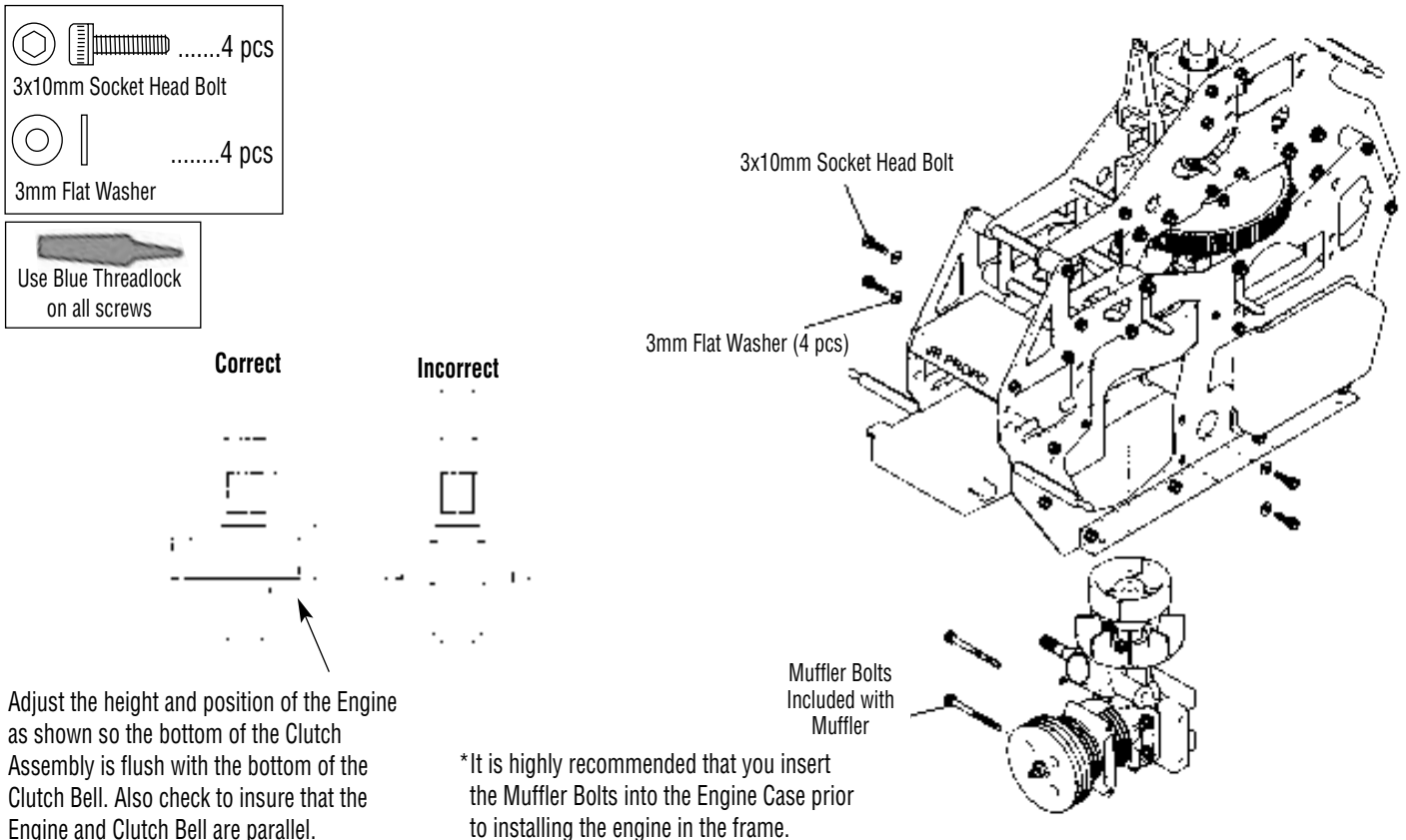

3-7

INSTALLATION OF THE MUFFLER

Note: The installation shown is for a .32-.38 size engine with a JR muffler (JRP960078). Installation of other .32-.38 engine muffler combinations may vary. Please refer to your engine/muffler instructions for proper installation.

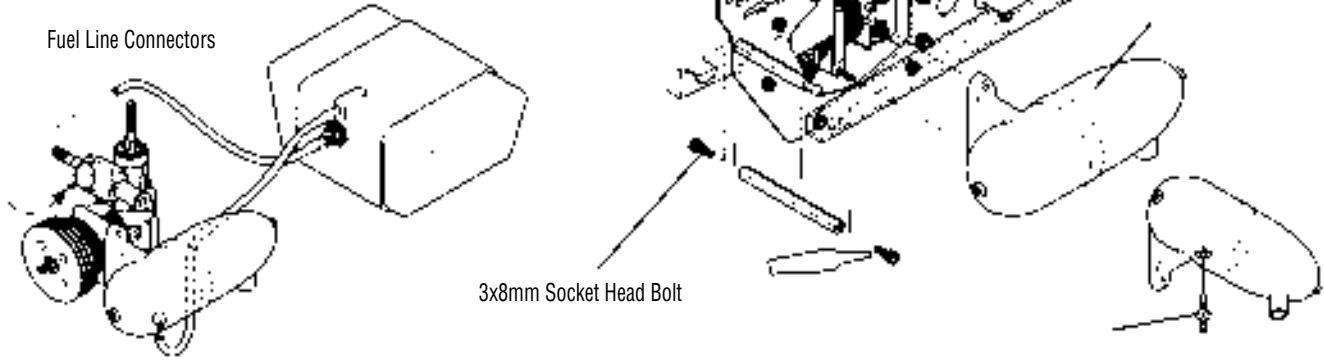
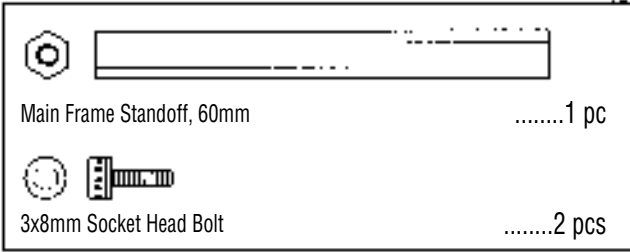

3-8

LANDING GEAR ASSEMBLY INSTALLATION

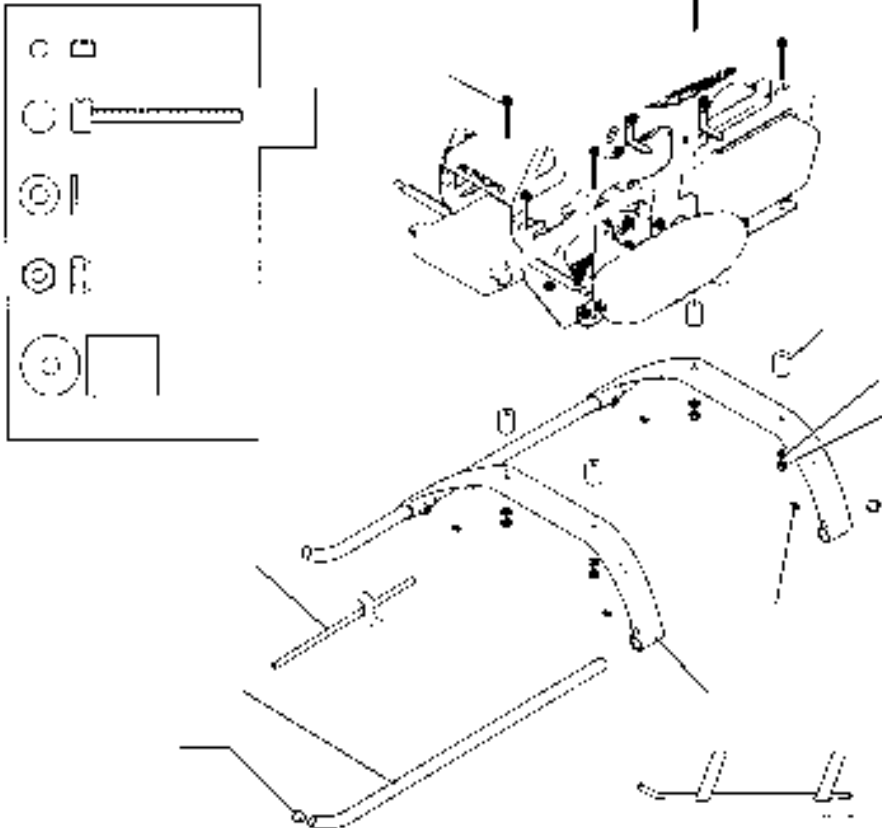

4-1

ROTOR HEAD HUB ASSEMBLY



-1 pc
3x6mm Socket Head Bolt
-2 pcs
3x8mm Socket Head Bolt

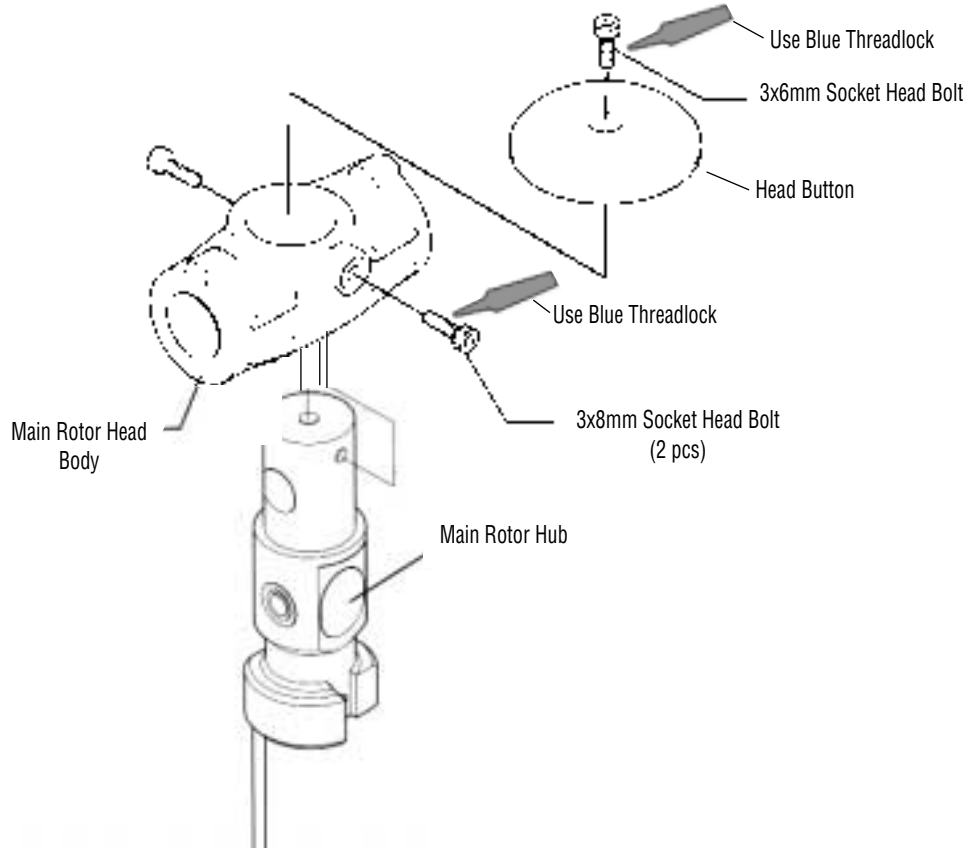

4-2

MAIN BLADE HOLDER ASSEMBLY



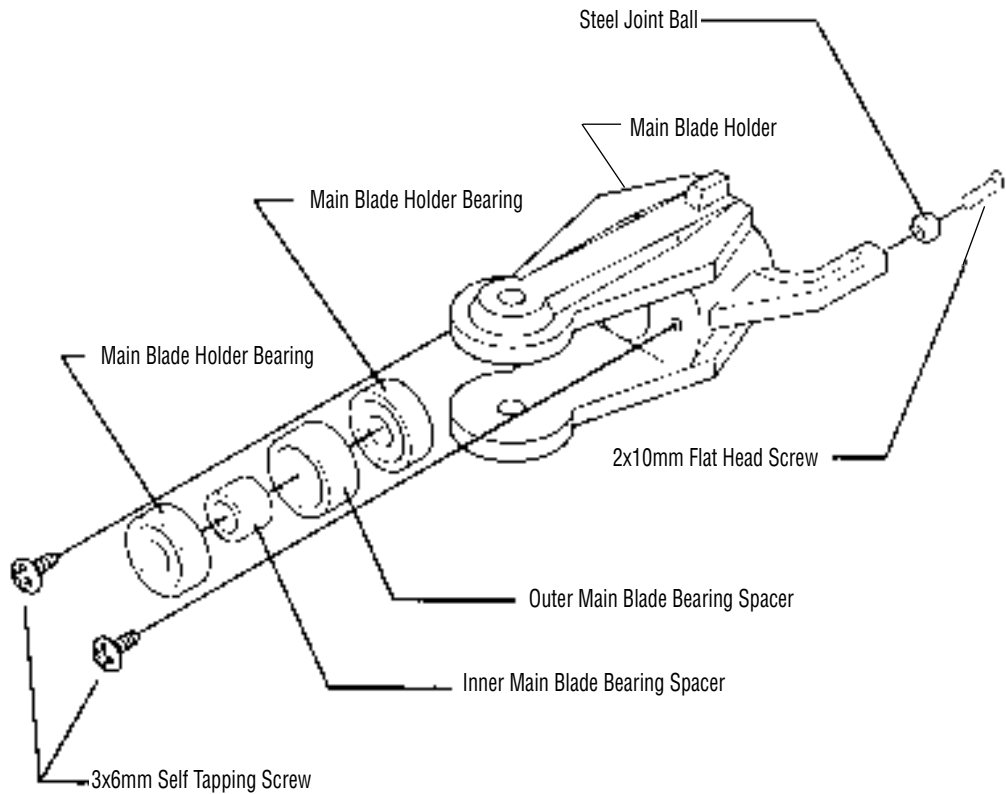

Two Sets Required

-4 pcs
3x6mm Self Tapping Screw
-1 pc
2x10mm Flat Head Screw
-1 pc
Steel Joint Ball
-2 pcs
Main Blade Holder Bearing
-1 pc
Outer Main Blade Bearing Spacer
-1 pc
Inner Main Blade Bearing Spacer



4-3

MAIN BLADE HOLDER/SEESAW ATTACHMENT

- 2 pcs
Seesaw Shaft bushing
- 2 pcs
3x5mm Button Head Bolt
- 2 pcs
4mm Lock Nut
- 2 pcs
Seesaw Spacer (Steel)
- 2 pcs
Blade Holder Spacer A

 Use Red Threadlock
4mm Lock Nut (2 pcs)

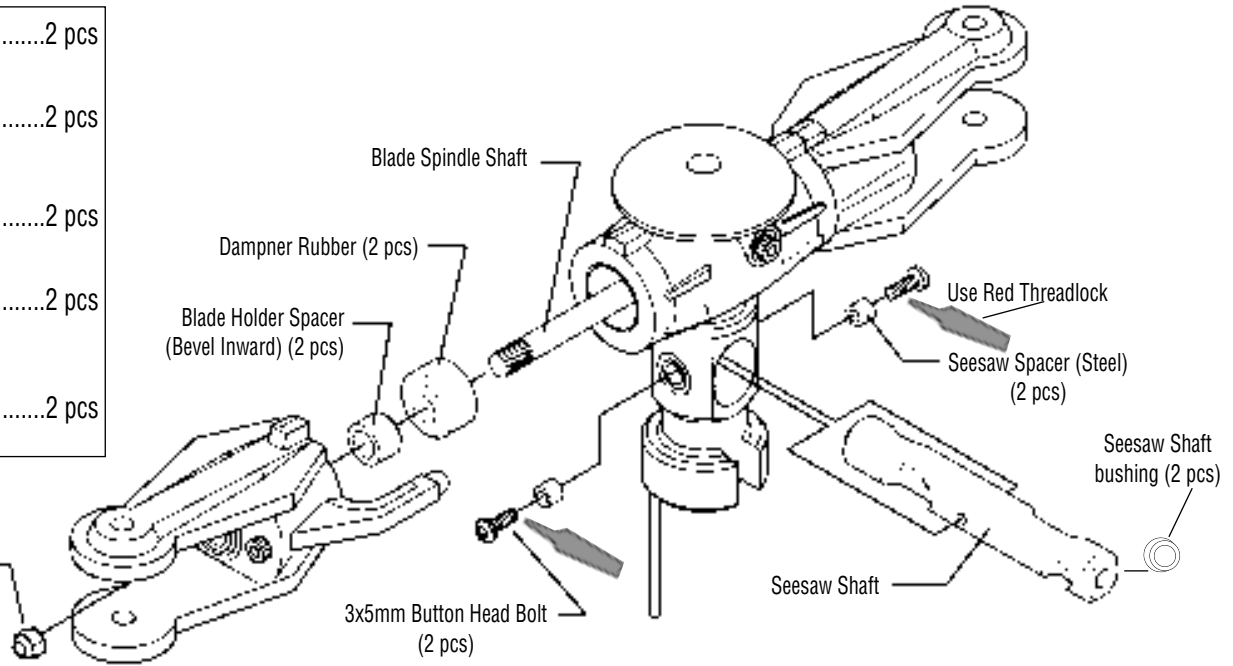







4-4

SEESAW MIXING ARM INSTALLATION

 Use Blue Threadlock

Two Sets Required

- 2 pcs
3x16mm Socket Head Bolt
- 4 pcs
2x10mm Flat Head Screw
- 6 pcs
3mm Flat Washer
- 4 pcs
Nylon Washer Shim
- 2 pcs
3x16mm Socket Head Bolt
- 4 pcs
Steel Joint Ball

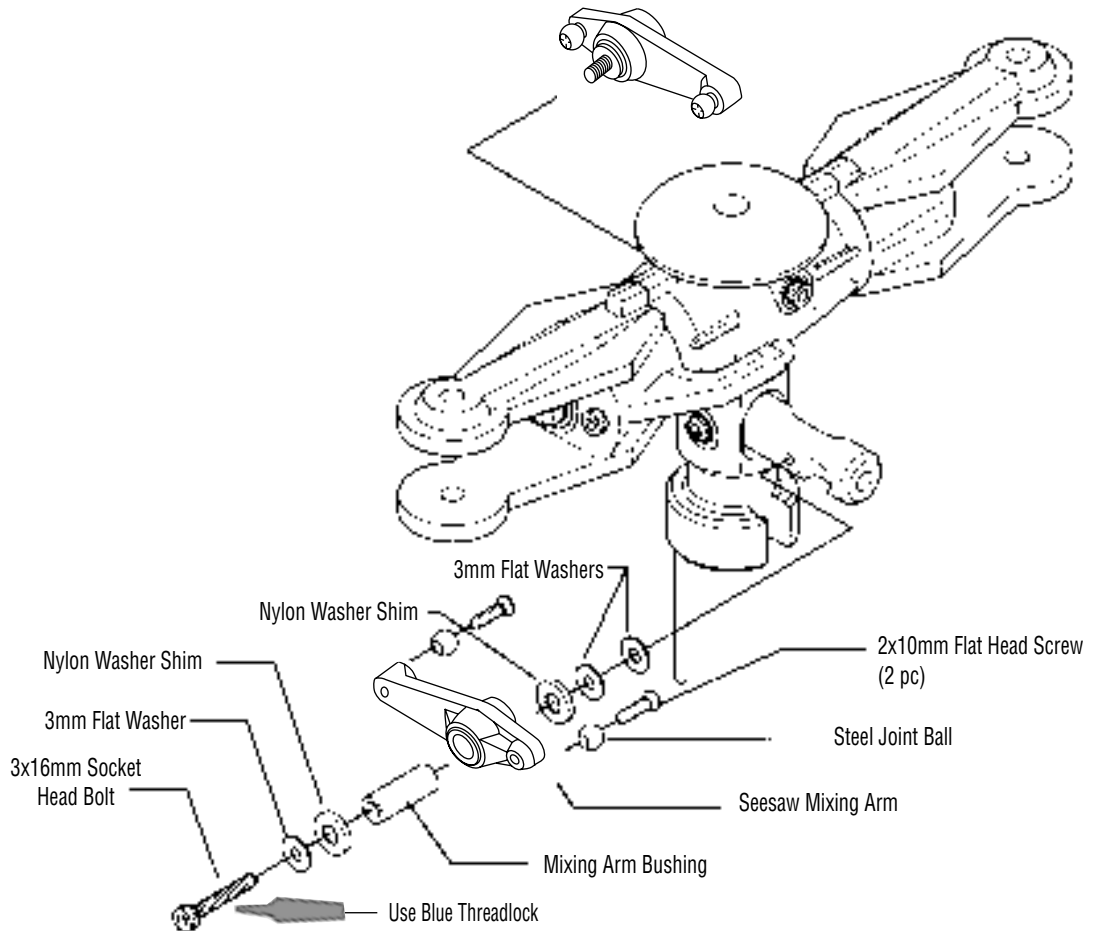

4-5

SWASHPLATE ADJUSTMENT

 3 pcs
4x4mm Set Screws

While holding the inside ball race, pivot the swashplate & check for excessive play. Adjust as necessary.



Swashplate Adjustment Test

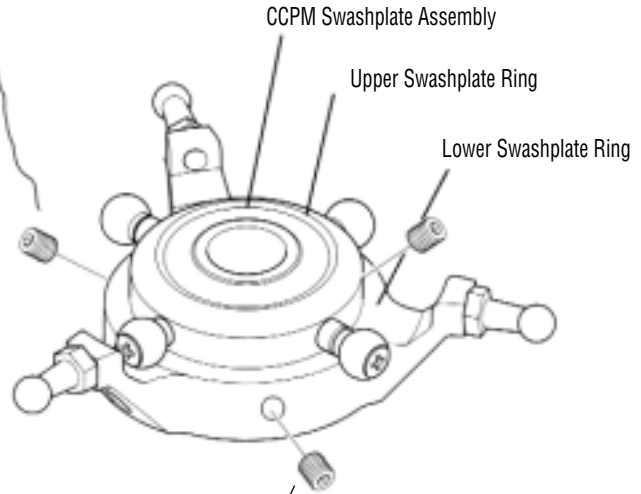

4x4mm Swashplate Adjusting Screws
(Caution: Do not overtighten!)

Swashplate Adjustment

The 120° CCPM swashplate is adjustable via the 3 – 4X4mm set screws. If excessive play is found in the test above, gently tighten each of the 3 – 4mm set screws the same amount and re-test. The swashplate should move freely, but without notable play.

Caution:

If the 3 – 4mm set screws are over tightened, damage to the swashplate bearings can occur.

4-6

SWASHPLATE/WASHOUT ASSEMBLY INSTALLATION

Note: The A-Arms on the Washout Assembly snap onto the balls that are extended on the ring on the Swashplate.

Option: For smooth operation, pre-size the ball links with the JR ball link sizing tool prior to attachment.

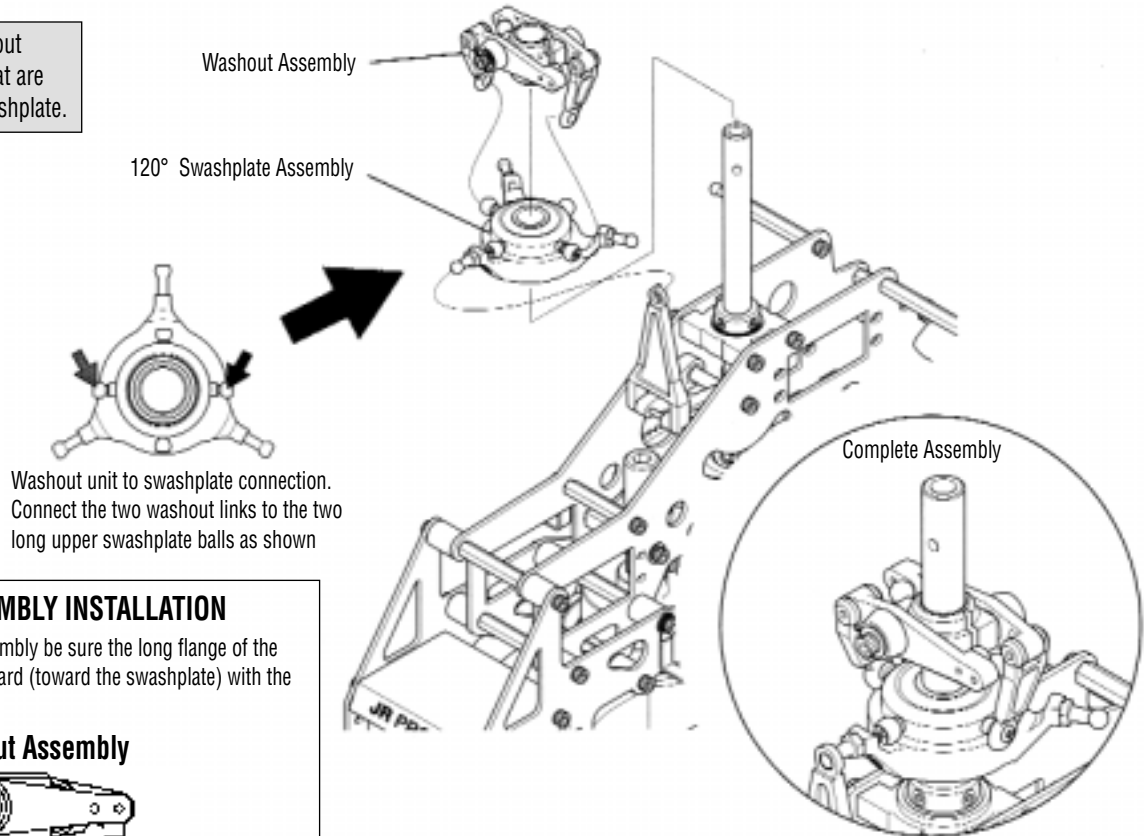

Washout unit to swashplate connection. Connect the two washout links to the two long upper swashplate balls as shown

*WASHOUT ASSEMBLY INSTALLATION

When installing the washout assembly be sure the long flange of the mixing base is positioned downward (toward the swashplate) with the short portion facing upward.

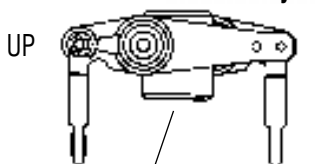

Washout Assembly



Long portion of mixing base flange must face downward.

4-7

ROTOR HEAD INSTALLATION

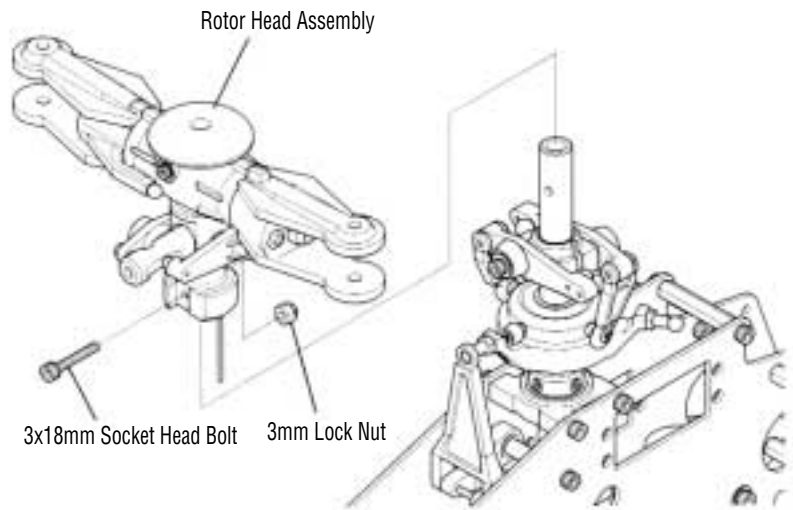

- 1 pc
3x18mm Socket Head Bolt
- 1 pc
3mm Lock Nut



Note: Be sure to engage the rotor hub pin into the washout base groove before securing the rotor head in place

4-8

FLYBAR INSTALLATION

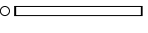
-  Use Blue Threadlock
- 2 pcs
4x4mm Set Screw
- 2 pcs
Flybar Bushings
- 2 pcs
Flybar Control Arm

* Be sure to insert Flybar Bushings into the Seesaw Shaft before inserting Flybar.

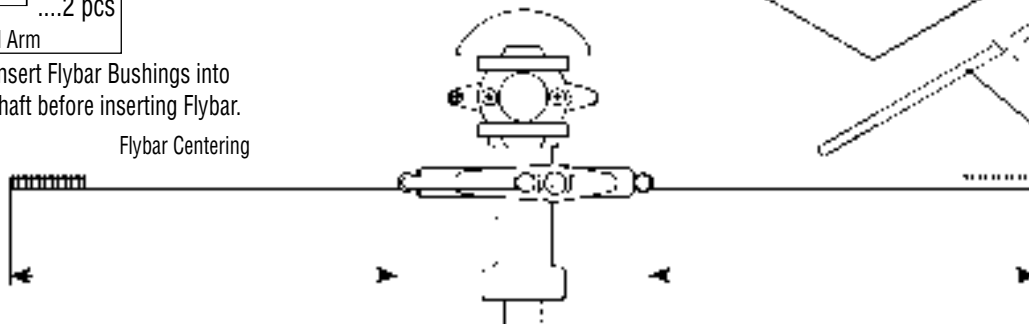
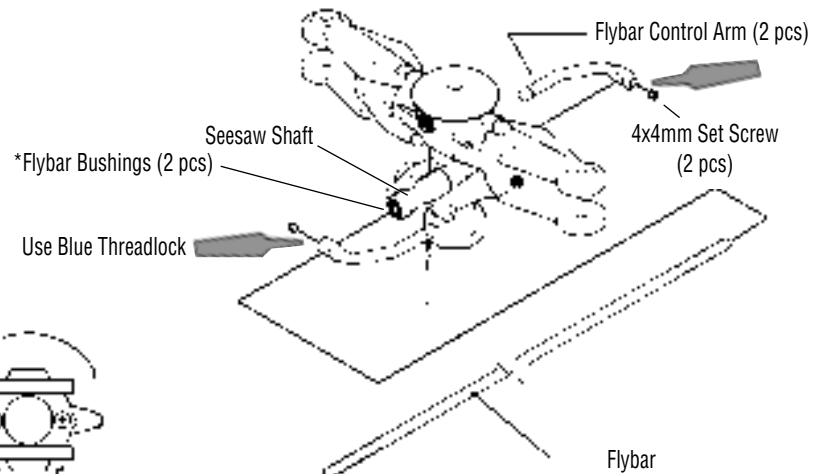

Note: Center the Flybar in the Seesaw Shaft before securing the two Flybar Control Arms.

Check to make sure the two Flybar Control Arms are parallel to the center line of the Flybar.

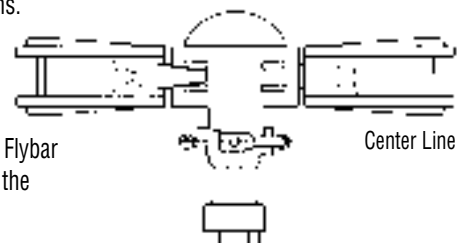

4-9

FLYBAR PADDLE ATTACHMENT



Thread each Flybar Paddle onto the Flybar until the threaded tip of the Flybar protrudes approximately 4mm.

Adjust each Flybar Paddle so they are parallel to the Flybar Control Arms and to each other. Secure to the Flybar using two 3mm lock nuts.

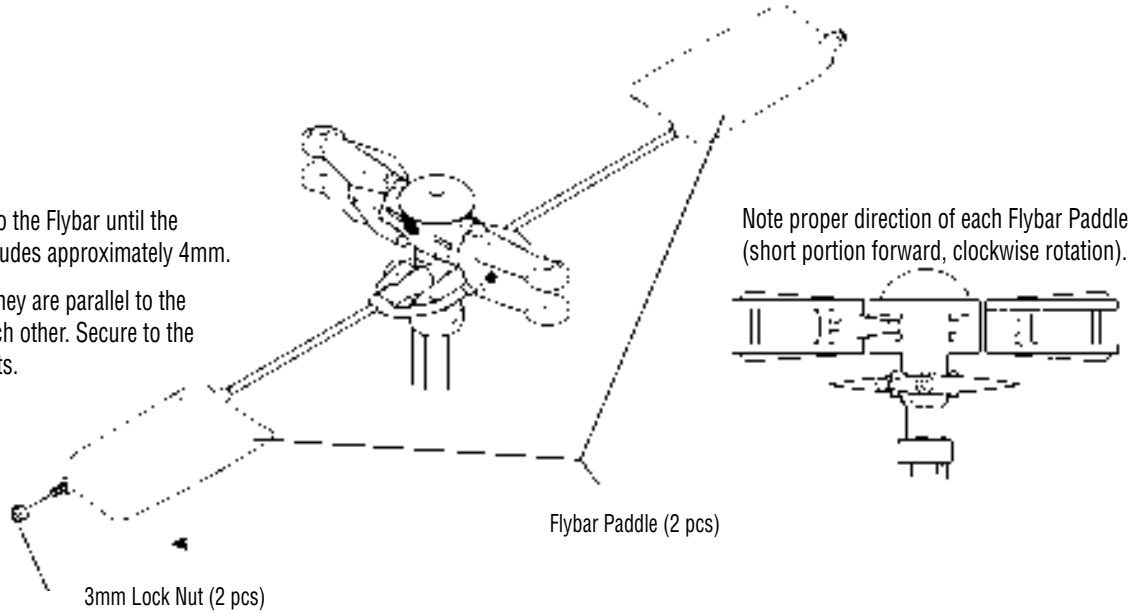

4-10

ROTOR HEAD/SWASHPLATE CONTROL ROD INSTALLATION

Option: For smooth operation, pre-size the ball links with the JR ball link sizing tool prior to attachment

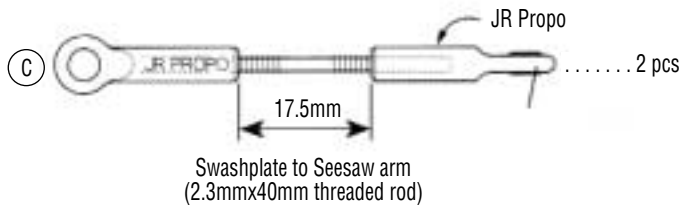
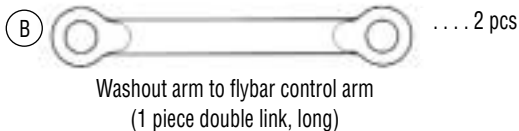
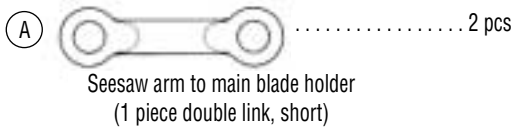
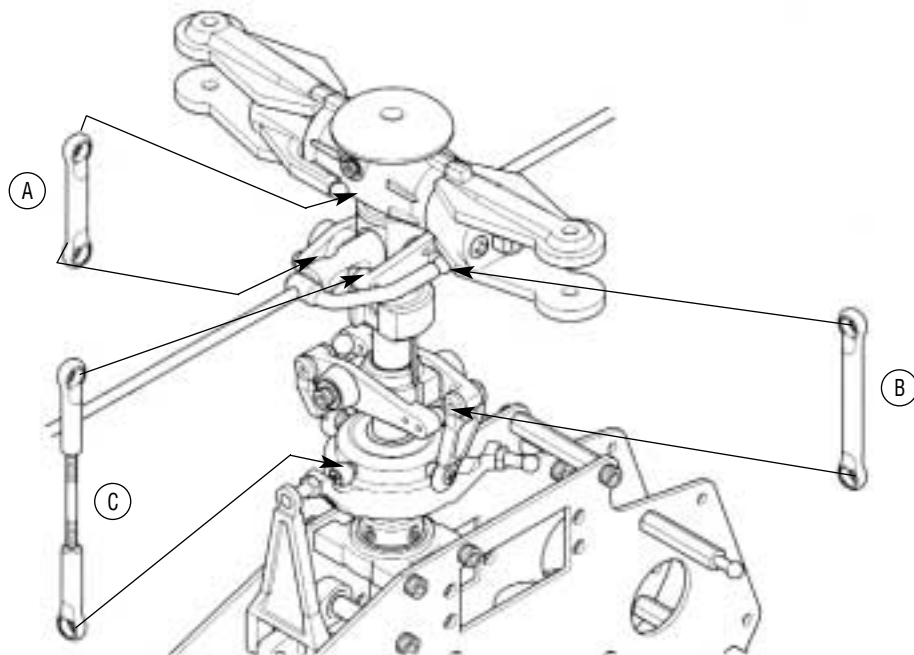

5-1

TAIL OUTPUT SHAFT/PULLEY ASSEMBLY

.....1 pc
Spring Pin

Pre-Assembled in kit

Complete Assembly

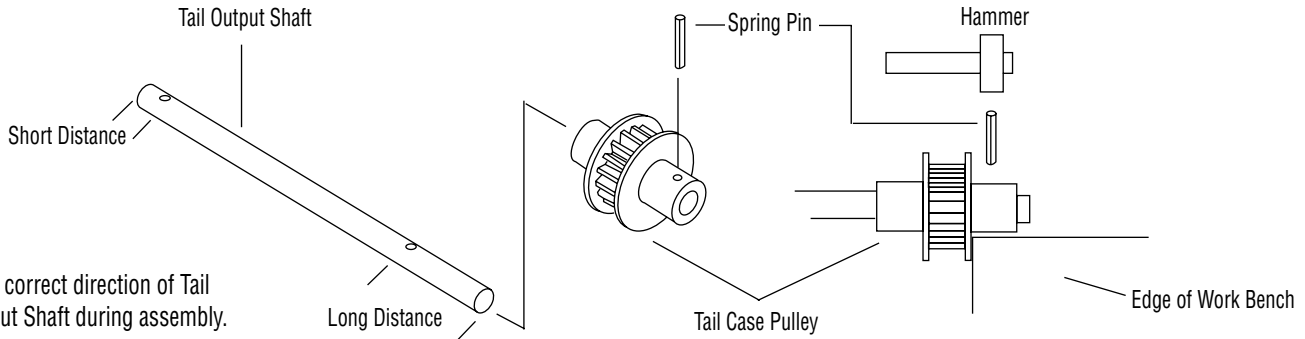
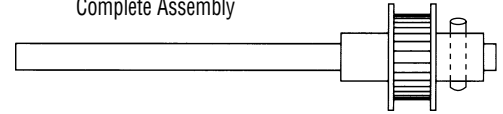

Note correct direction of Tail Output Shaft during assembly.

5-2

TAIL GEAR CASE ASSEMBLY

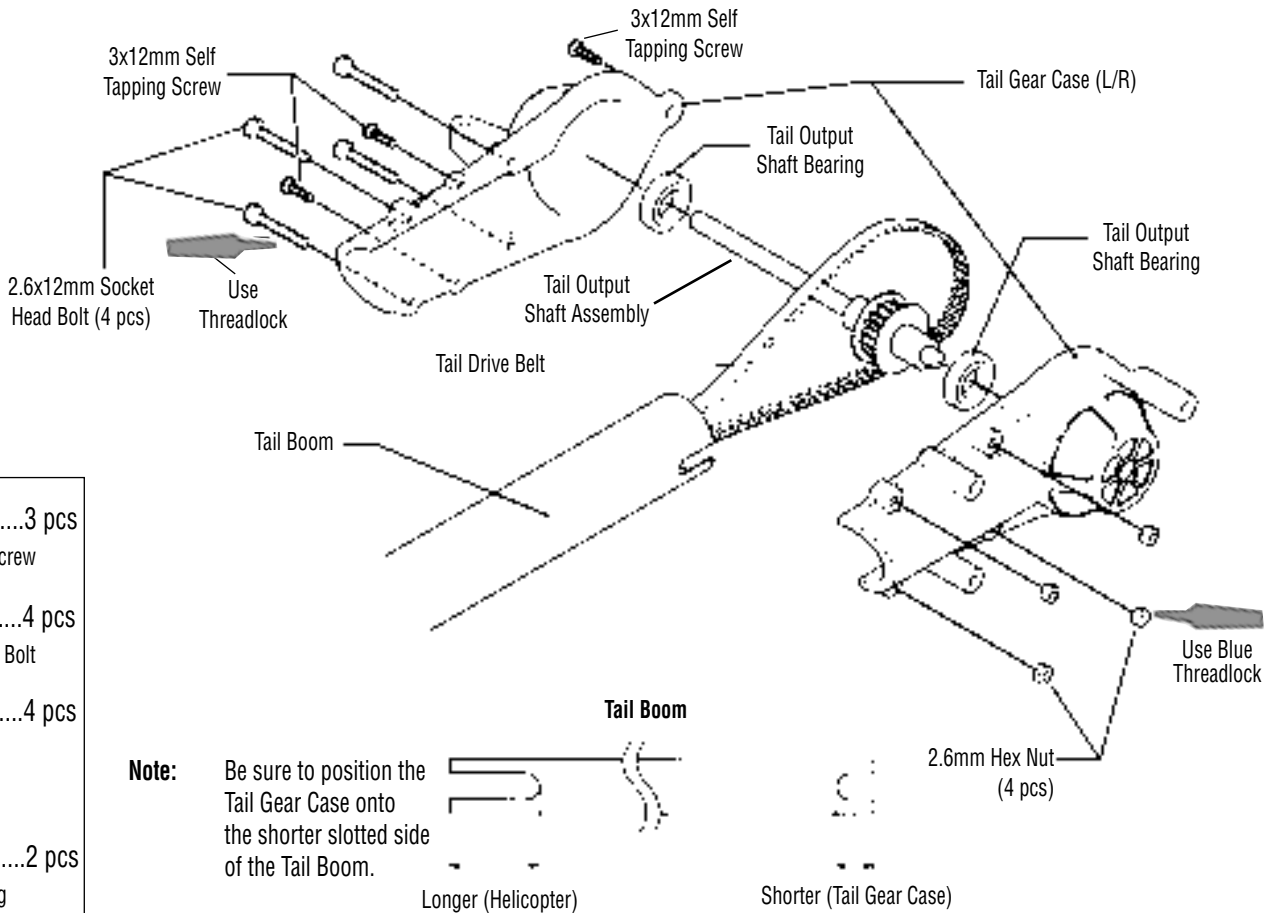

Use Blue Threadlock

-3 pcs
3x12mm Self Tapping Screw
-4 pcs
2.6x12mm Socket Head Bolt
-4 pcs
2.6mm Hex Nut
-2 pcs
Tail Output Shaft Bearing

Note: Be sure to position the Tail Gear Case onto the shorter slotted side of the Tail Boom.

Longer (Helicopter)

Shorter (Tail Gear Case)

5-3

TAIL CENTER HUB ASSEMBLY

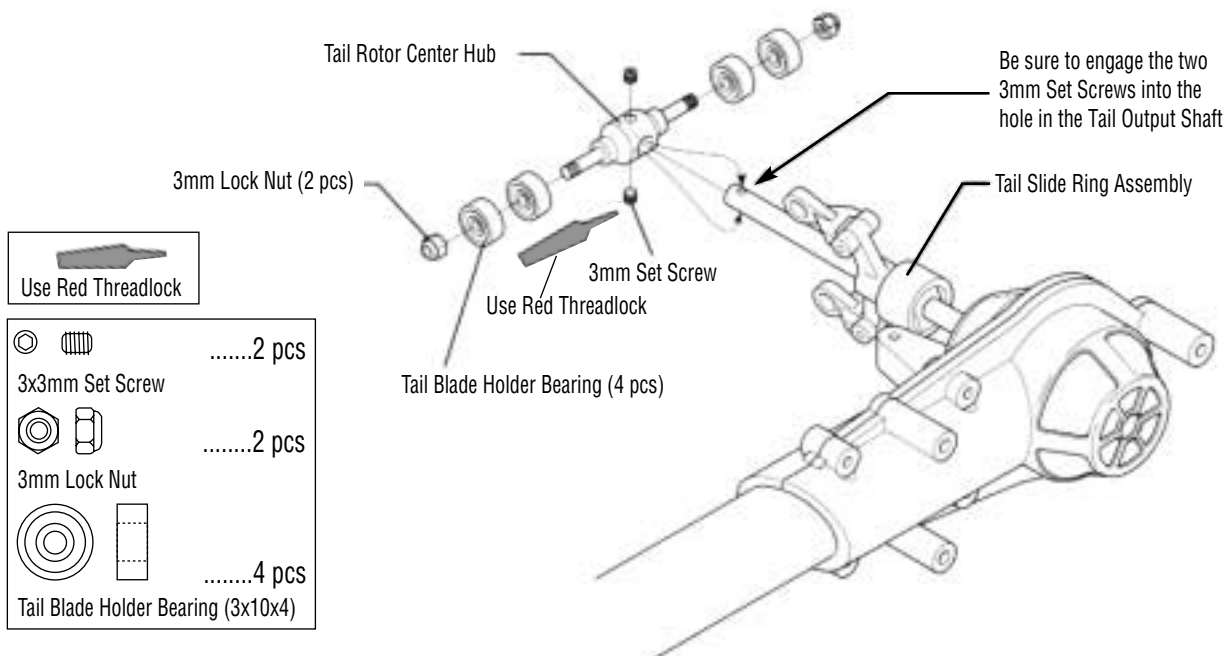

- Use Red Threadlock
-2 pcs
 -2 pcs
 -4 pcs
- Tail Blade Holder Bearing (3x10x4)

5-4

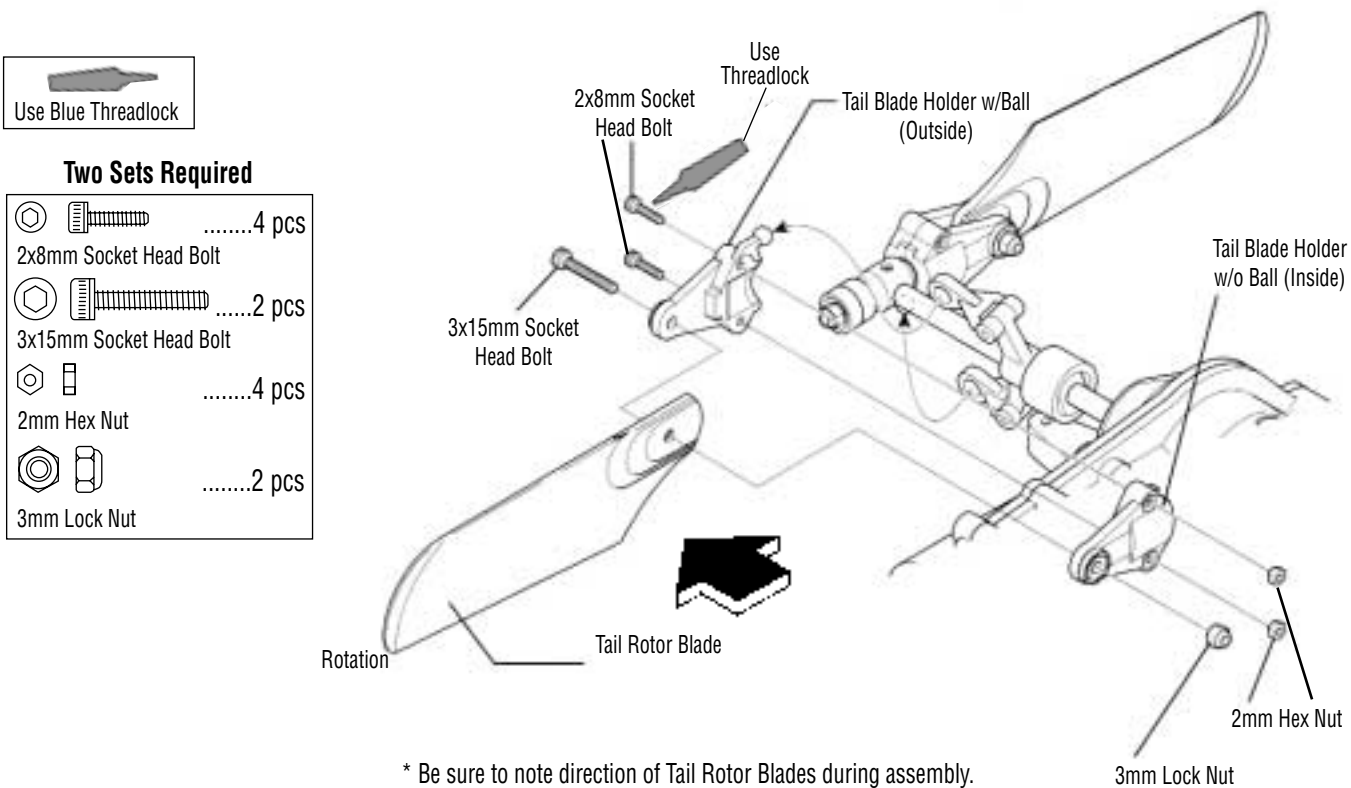

TAIL BLADE HOLDER ASSEMBLY



- Use Blue Threadlock
- Two Sets Required**
-4 pcs
 -2 pcs
 -4 pcs
 -2 pcs

5-5

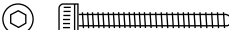

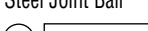
TAIL PITCH CONTROL LEVER INSTALLATION

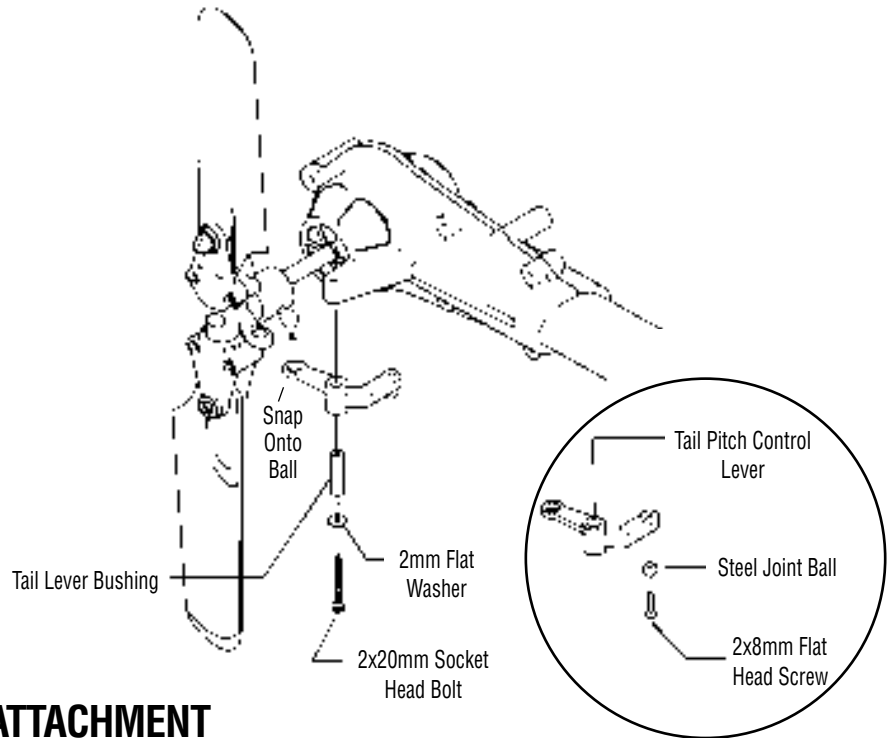
1 pc
2x8 Flat Head Screw	
1 pc
2x20mm Socket Head Bolt	
1 pc
2mm Flat Washer	
1 pc
Steel Joint Ball	
1 pc
Tail Lever Bushing	



5-6

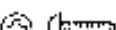
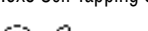

TAIL FIN ATTACHMENT

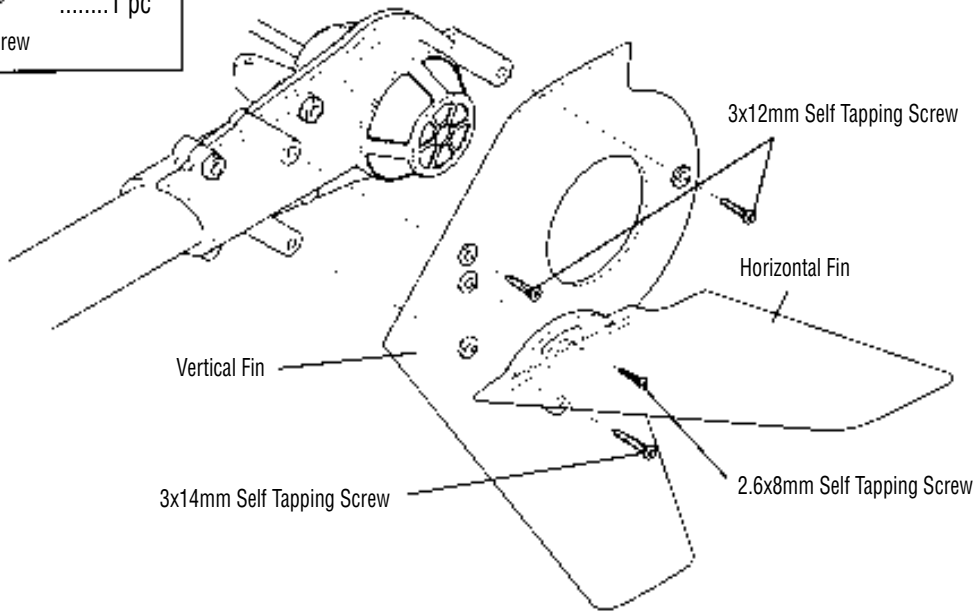
1 pc
2.6x8 Self Tapping Screw	
2 pcs
3x12 Self Tapping Screw	
1 pc
3x14 Self Tapping Screw	



5-7

TAIL BOOM CARRIER INSTALLATION

4 pcs
2 pcs
6 pcs

* Do not fully tighten at this time. These bolts will be secured in Step 5-10.

**Note: For increased tail boom mounting strength, it is suggested that the 2 halves of the tail boom carrier be sanded on a flat surface using 80-100 grit sandpaper. By removing material from the inside flange, a more positive tail boom connection can be achieved.

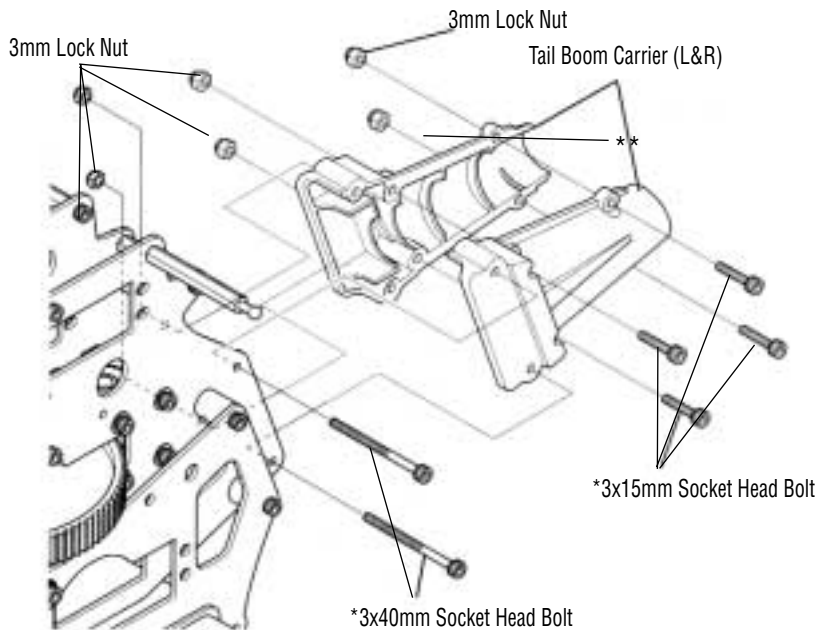

5-8

TAIL BOOM ASSEMBLY INSTALLATION

Slide the Tail Boom through the Tail Boom Carrier and engage the Tail Drive Belt over the Front Pulley. Be certain to note the correct rotation (direction shown below). Set the belt tension per the directions below.

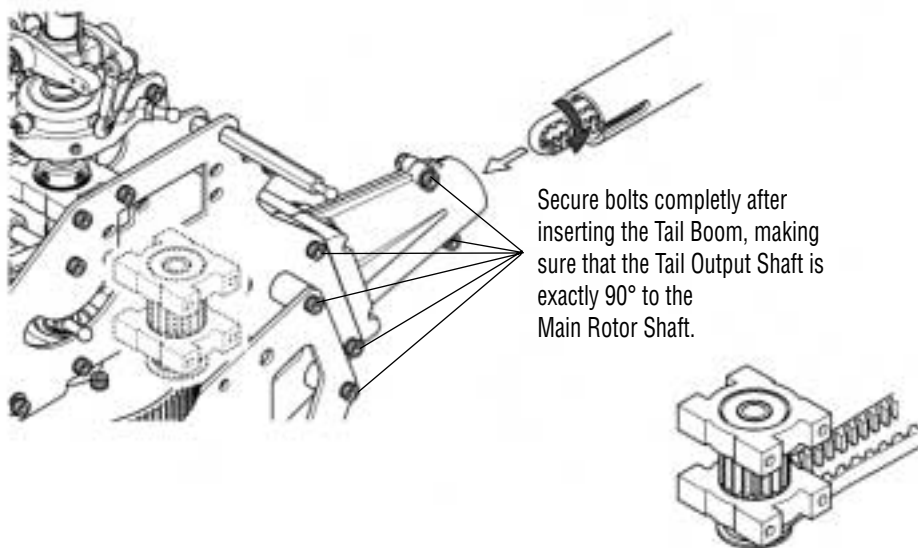

Belt tension should be set so when pressing with your finger, the sides of the belt do NOT come in contact with each other. If unsure, it is always better to set the belt tension too tight than too loose.

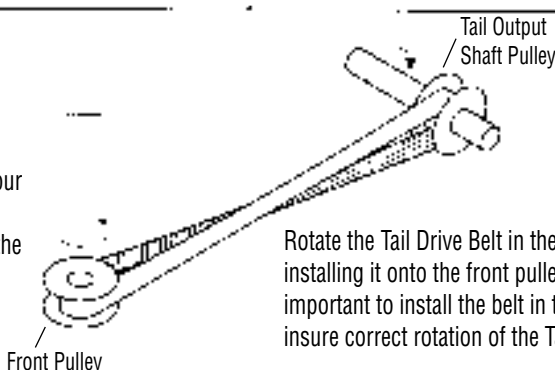

Rotate the Tail Drive Belt in the direction shown before installing it onto the front pulley. It is extremely important to install the belt in the proper direction to insure correct rotation of the Tail Rotor Blades.

5-9

TAIL BOOM BRACE ASSEMBLY

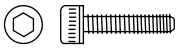
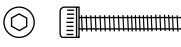



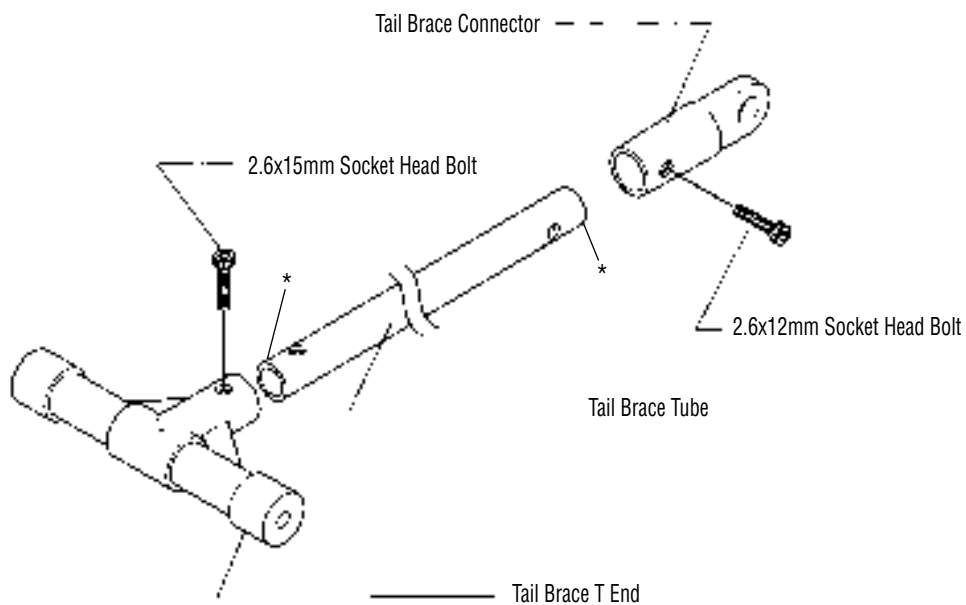

-  1 pc
2.6x12mm Socket Head Bolt
-  1 pc
2.6x15mm Socket Head Bolt

* For added boom brace strength, bond the tail brace ends to the tube after assembly with thick CA adhesive.



5-10

TAIL BOOM BRACE INSTALLATION

-  2 pcs
3x8mm Socket Head Bolt
-  2 pcs
3x12mm Socket Head Bolt
-  2 pcs
2.6x15mm Socket Head Bolt
-  2 pcs
3mm Lock Nut
-  2 pcs
2.6mm Lock Nut
-  1 pc
3mm Plastic Spacer

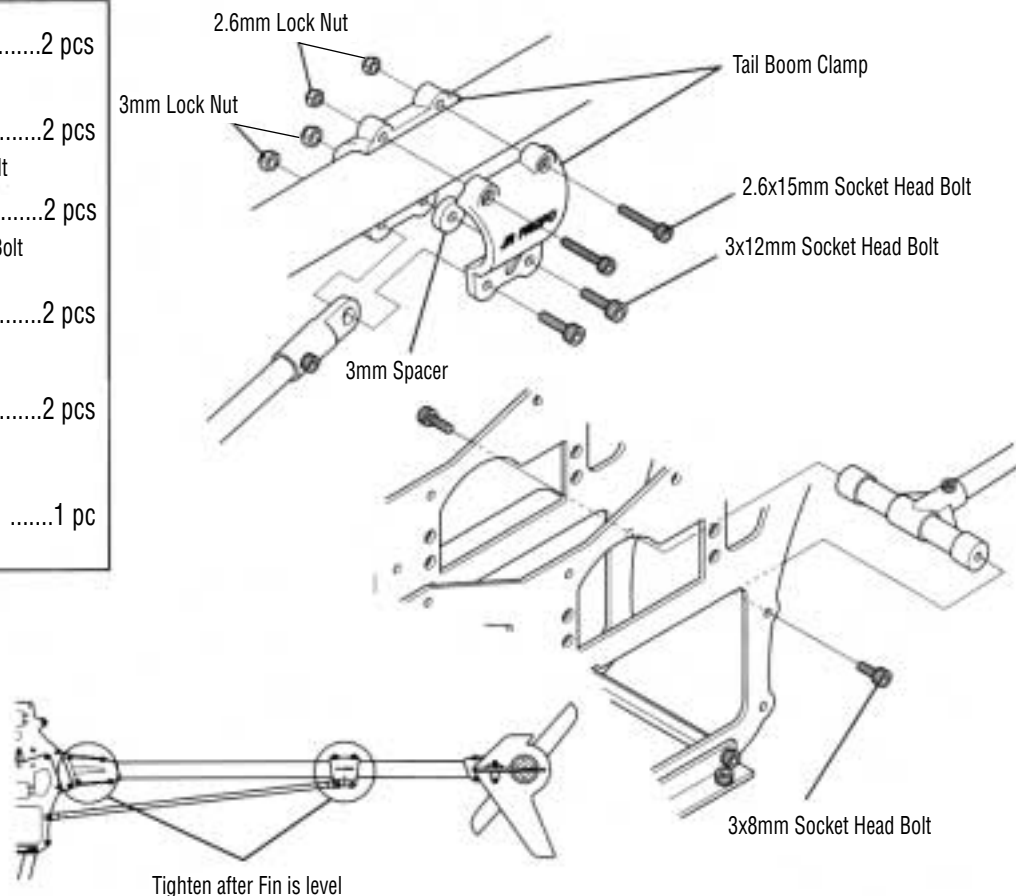

6-1

SERVO INSTALLATION

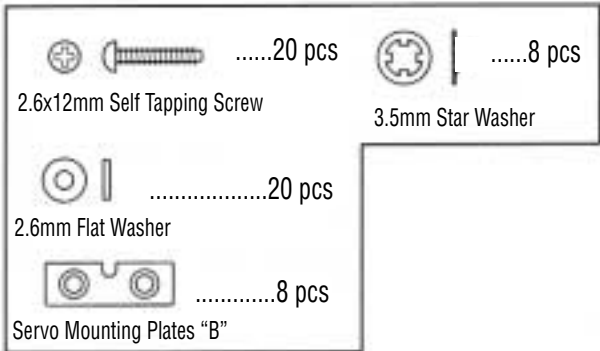

RADIO INSTALLATION SUGGESTIONS

Be sure to install four rubber servo grommets and eyelets to each servo prior to installation. When securing the servos to the helicopter, be sure not to over-tighten the mounting screws.

When adjusting control rods, be sure to adjust each universal link the same amount so as not to unthread one link too far.

Be sure to keep all servo lead wires, etc., away from all servo arms, rods, and sharp edges of the helicopter's mechanics. After final installation, group these wires together as indicated using the small nylon wire ties and the nylon spiral tubing included with this kit.

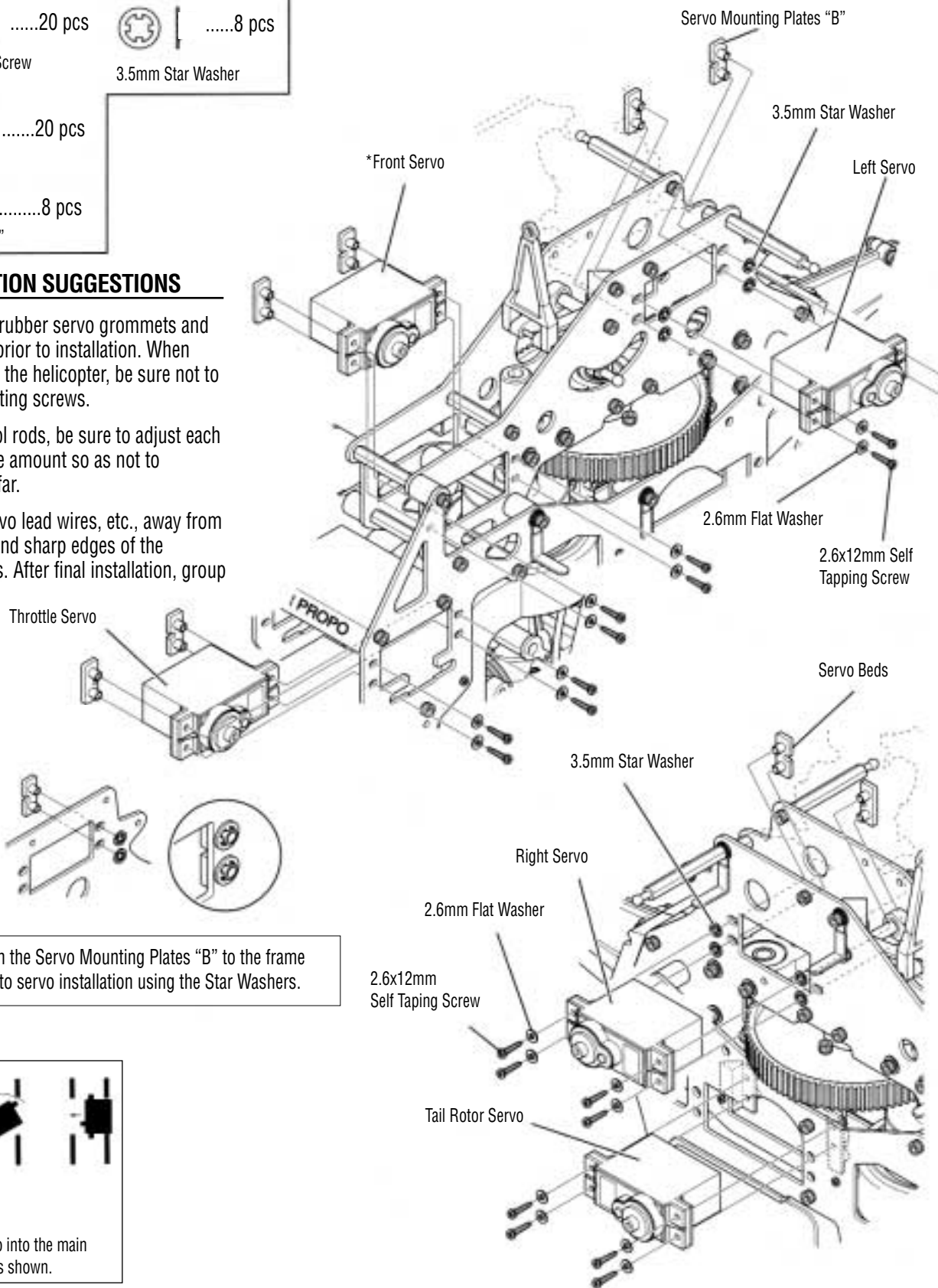

Attach the Servo Mounting Plates "B" to the frame prior to servo installation using the Star Washers.

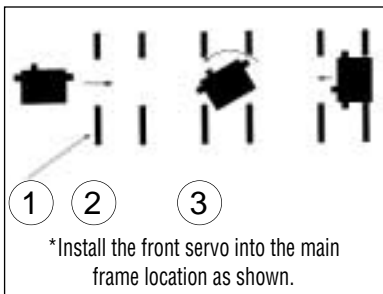

6-2

TAIL CONTROL ROD ASSEMBLY

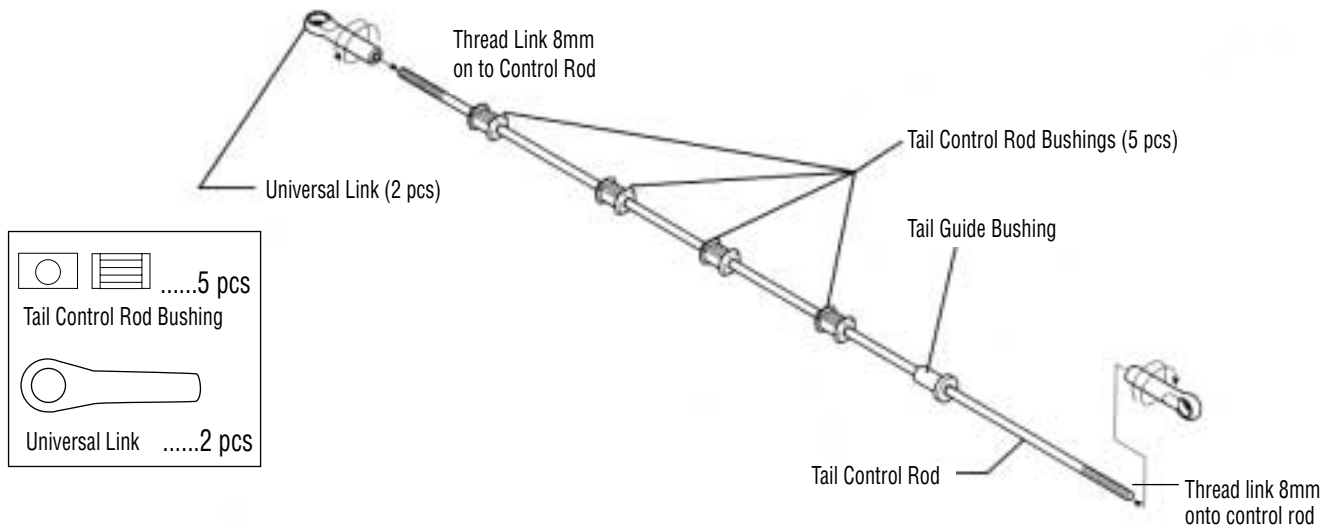

6-3

TAIL CONTROL ROD INSTALLATION

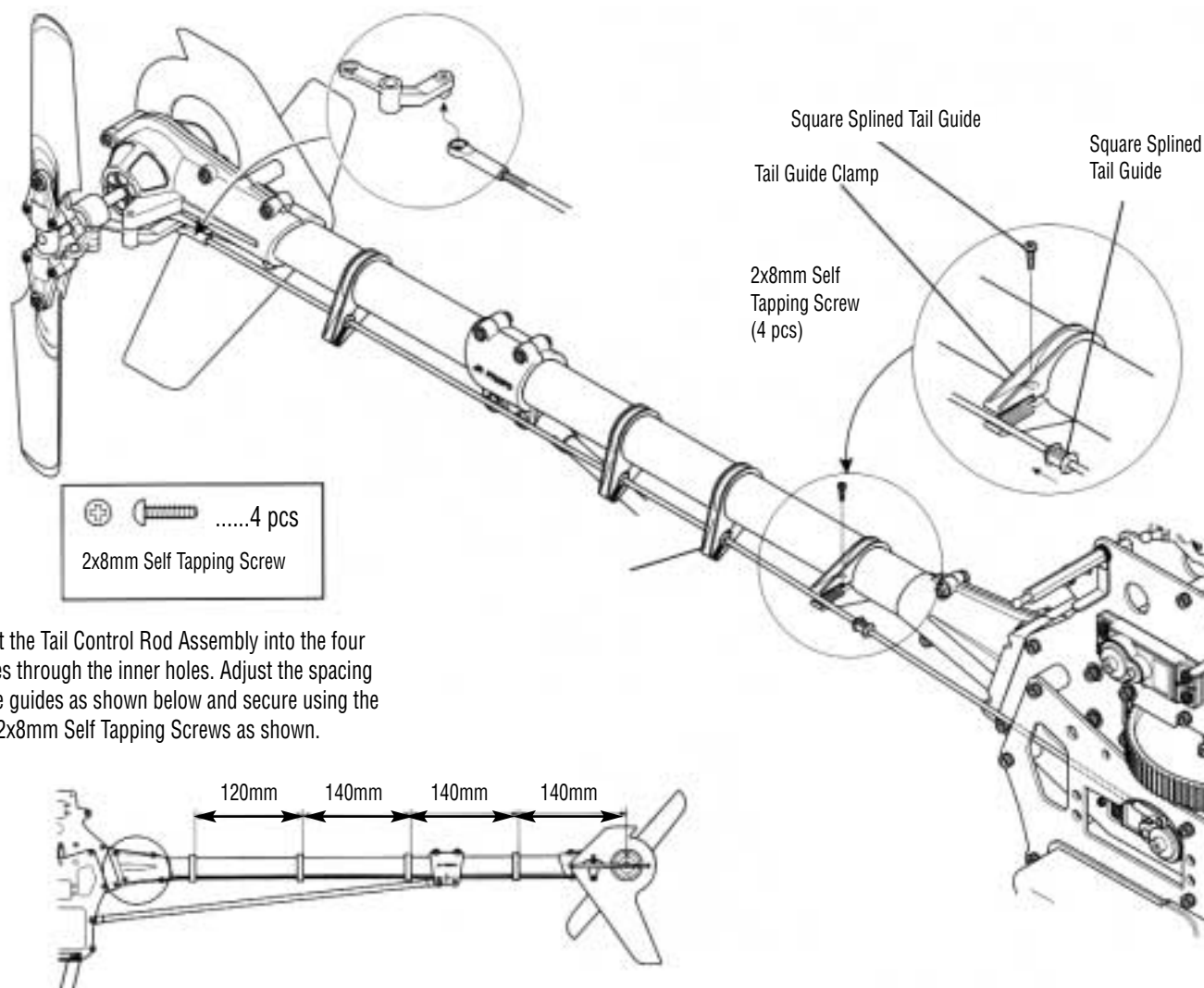

6-4

GYRO/RECEIVER/SWITCH HARNESS/BATTERY INSTALLATION

Caution: Be certain when installing the Gyro to the Gyro Mounting Plate that it does not come into contact with the frame of the helicopter and that the surfaces are free from oil, residue, etc. Clean if necessary to insure proper adhesion.

It is suggested that both the receiver and gyro amplifier be isolated from vibration by wrapping them in foam, then securing them to the model using double-sided servo tape.

Note: Nylon Wire Ties and Double Sided Servo Tape are not included in this kit.

*Wrap with foam or sponge rubber individually before installation.

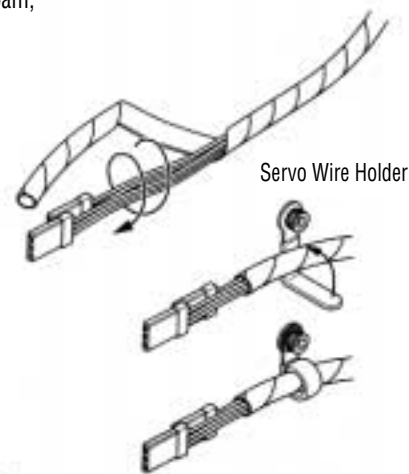
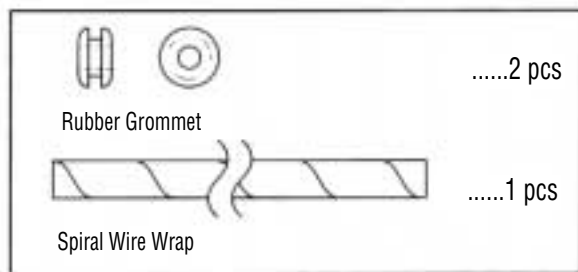

Wrap the Servo wires using the spiral wire wrap as shown.

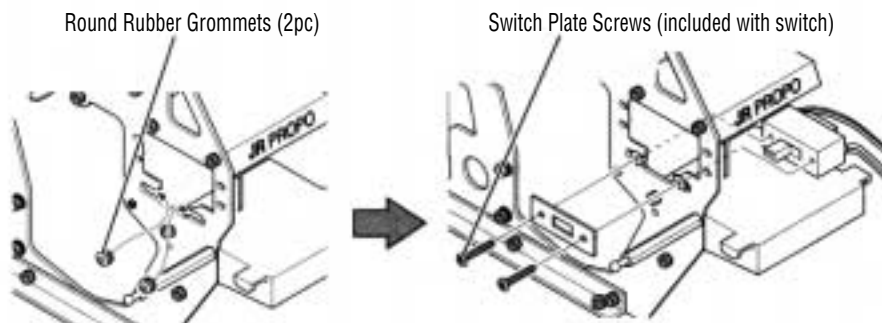
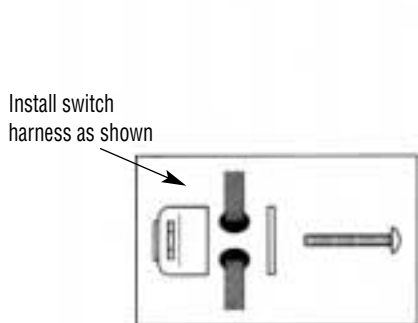
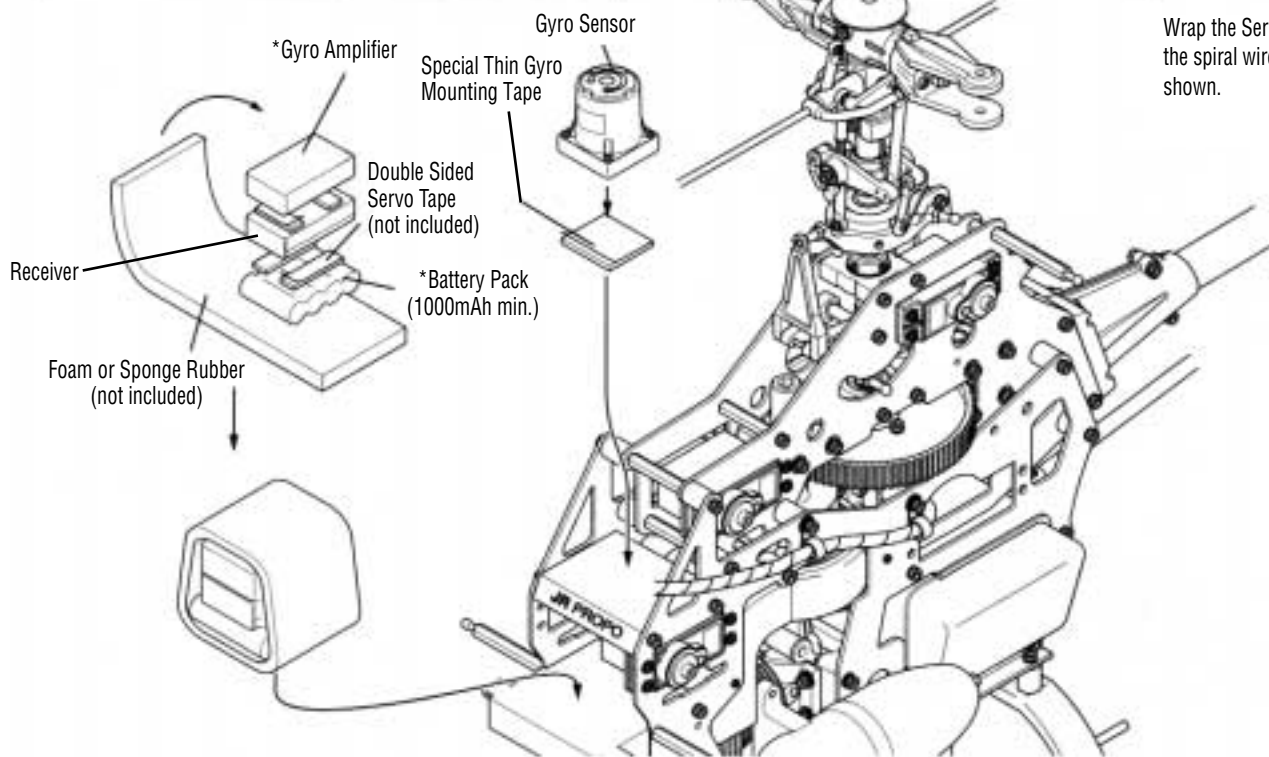

Currently, there are several different types of control systems available on the market. Although the mechanical methods for transferring control to the swashplate vary, the different control systems can be broken down into two categories: 1 Servo (conventional) and CCPM (Cyclic/ Collective Pitch Mixing).

The following is an explanation of the two most popular types of swashplate control.

1. 1 Servo Standard Swashplate Control

The 1 Servo Standard System is found in a wide variety of radio controlled helicopters. The term "1 Servo" means that the control system requires one servo to operate each separate swashplate function. With this system, a total of three servos is required to operate the three main swashplate functions, which are Aileron (roll), Elevator (pitch) and Collective functions. With this type of control system, each servo works independently and is assigned to a specific function. In other words, the Aileron (roll) servo is assigned to move only the Aileron (roll) function, as is the Elevator (pitch) servo, etc. Since these servos operate completely independently of each other, the servo torque to each control surface is limited to the maximum torque rating of the servos used.

The 1 Servo Standard system swashplate is designed so that the lower swashplate ring control balls are spaced at 90° to each other. This system is also most commonly arranged so that the Aileron (roll) axis of the swashplate is positioned at 90° to the main mechanics of the helicopter, and the Elevator (pitch) axis is parallel to the mechanics. Please refer to the diagram at right for clarification.

With this type of system, it is necessary for the helicopter to be designed using an intermediate mechanical mixing system so that the control inputs can be transferred from the three independent servos to the swashplate in such a manner that the three controls can be achieved. This mechanical mixing system allows the swashplate to both Roll (Aileron) and Pitch (Elevator), as well as slide up and down the main rotor shaft for Collective pitch inputs. These mechanical mixing systems generally require the use of many ball bearings and control rods to achieve this result.

Standard "1 Servo" Swashplate System

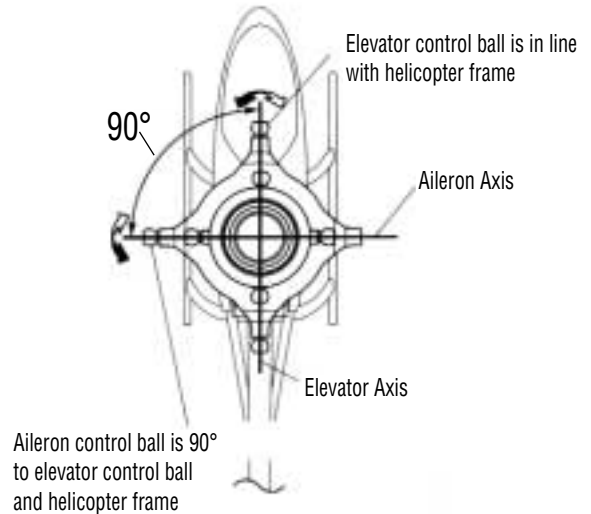

2. 120° 3-Servo CCPM Swashplate Mixing

The JR 120° CCPM, or Cyclic/Collective Pitch Mixing, system offers the user a control system that can accomplish the same control inputs as the 1 Servo Standard system mentioned above, but with increased precision and reduced complexity.

As with the 1 Servo system, the JR CCPM system utilizes three servos for the three main controls: Aileron (roll), Elevator (pitch) and Collective. The CCPM lower swashplate ring is designed with only three control balls, spaced at 120° from each other, hence the 120° CCPM designation. Although the control balls are not at 90° as in the standard system, the Aileron (roll) axis is still parallel to the main mechanics of the helicopter, and the elevator (pitch) axis still functions at 90° to the mechanics as does the 1 Servo System. Please refer to the diagram below for clarification.

The main and important difference in the way that these two systems operate is that unlike the 1 servo system where the three servos work completely independent from each other, the CCPM systems work as a team to achieve the same control inputs. For example, if an Aileron (roll) input is given, two servos work together to move the swashplate left and right. If an Elevator (pitch) input is given, all three servos work together to move the swashplate fore and aft. For collective, it's also the strength of three servos that will move the swashplate up and down the main rotor shaft. With 2 to 3 servos working at the same time during any given control input, servo torque is maximized and servo centering is also increased. In addition to these benefits, CCPM achieves these control responses without the need for complex mechanical mixing systems that require many more control rods and parts to set up.

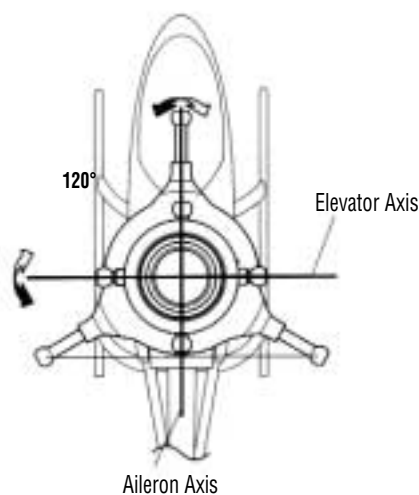

JR 120° 3 Servo CCPM Control System

This amazing CCPM control is achieved through special CCPM Swashplate Mixing that is pre-programmed into many of today's popular radio systems.

Since the 120° CCPM function is pre-programmed, CCPM is no more complicated to set up than a conventional 1 Servo Standard system. When you factor in the reduced parts count and easy programming, CCPM is actually easier to set up and operate than many conventional systems.

For JR radio owners, please refer to the radio information contained at the front of this manual or on the following page to determine if your radio system has the CCPM function.

For other brands of radio systems, please contact the radio manufacturer for CCPM information. Please note that it is not possible to program a non-CCPM radio system for CCPM operation.

HOW JR 120° CCPM WORKS

As mentioned previously, JR 120° three Servo CCPM relies on the radio's special CCPM Swashplate Mixing, rather than a conventional mechanical mixer that is utilized to achieve the same results.

The radio's 120° 3-Servo CCPM function automatically mixes the three servos to provide the correct mixing inputs for Aileron (roll), Elevator (pitch) and Collective. The following is an example of how each control input affects the servo's movement:

1. Collective

When a collective pitch input is given, all three servos (A, B, and C) move together in the same direction, at equal amounts, to raise and lower the swashplate while keeping the swashplate level. During this function, all three servos travel at the same value (100%) so that the swashplate can remain level during the increase and decrease in pitch. As mentioned, this mixing of the three servos is achieved through the radio's CCPM program.

2. Elevator (pitch)

When an elevator input is given, all three servos must move to tilt the swashplate fore and aft, but their directions vary. The two rear servos (B and C) move together in the same direction, while the front servo (A) moves in the opposite direction. For example, when an up elevator (back cyclic) command is given, the two rear servos (B and C) will move downward, while the front servo (A) moves upward so that the swashplate will tilt aft. During this function, the front servo (A) travels at 100%, while the two rear servos (B and C) travel at 50% (1/2 the travel value) of the front servo. This difference in travel is necessary due to the fact that the position of the front control ball is two times the distance of the two rear control ball position as measured from the center of the swashplate. As mentioned, this mixing of the three servos is also achieved through the radio's CCPM program.

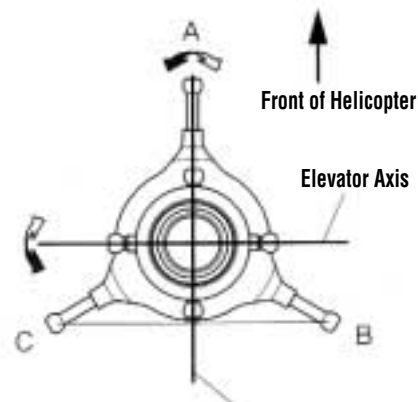

JR 120° CCPM Control System

3. Aileron (roll)

When an aileron (roll) input is given, the two rear servos (B and C) travel in opposite directions, while the front servo (A) remains motionless. For example, when a left aileron (roll) command is given, the left rear servo (C) will move downward, while the right rear servo (B) will move upward to tilt the swashplate to the left. As mentioned, the front servo (A) will remain motionless. The travel value for each of the two rear servos is 100%.

Please refer to the diagram at right for clarification.

RADIO SYSTEM REQUIREMENTS (NOT INCLUDED):

6-channel or greater R/C helicopter system with 120° CCPM function (see list below), 5 servos, 1000 mAh receiver battery and gyro.

CCPM-Ready JR Radio Systems

Most current JR Heli radio systems (XP652, XP8103 w/digital trims, 10X, as well as older 10 series systems) are equipped with 120° CCPM electronics for use with the Ergo CCPM machines. Radios you may be flying now, like the X347, X388S, XP783, and XP8103* have CCPM capability built in, but require activation by the

Horizon Service Department.

Please call (217) 355-9511 for details.

*Please note that many XP8103 systems have the CCPM function already activated. Please check with the Horizon Service Center.

CURRENT RADIO SYSTEMS

JRP1656** PCM 10X, 5-8231 Servos (50/53/72 MHz)
JRP165TX PCM 10X, Transmitter Only (50/53/72 MHz)
JRP8622** XP8103FM, 5-517 Servos (50/53/72 MHz)
JRP8653** XP8103PCM, 5-531 Servos (50/53/72 MHz)
JRP6622** XP652 FM, 5-517 Servos (50/53/72 MHz)



XP652

10X

XP8103 DT

1. JR 10 SERIES SYSTEMS

The following activation and set-up procedure should be used for all JR PCM10, 10S, 10SX, 10SxII, and 10X systems.

Prior to activating the CCPM function, it is first suggested that a Data Reset Function be performed to reset the desired model number to be used back to the factory default settings.

Caution: prior to performing the Data Reset Function, it will be necessary to select the desired model number to be used. Access the Model Select Function (Code 84) and select the desired model to be used.

SET-UP PROCEDURE

- A) Access the Data Reset Function (Code 28) once the correct model number has been established. Next, press the CLEAR key to reset the current model. Press the ENTER key to exit the Data Reset Function.

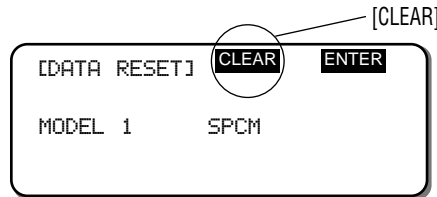

- B) Access the Swash Type Function (Code 65). Next, press the SEL key until 3 SERVOS (120°) appear on the screen. Once this is complete, it will be necessary to change the value of the Pitch Function from the factory default setting of +60, to a value of -50 using the + and - keys below the pitch value. Press ENTER to exit the Swash Type Function.

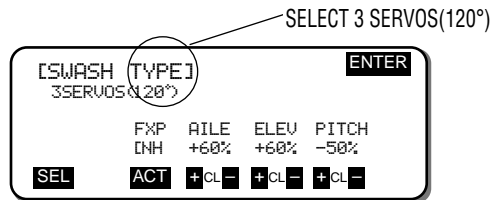

- C) Access the Servo Reversing Function (Code 11). Next, reverse channels 1, 2, and 4 by pressing the desired channel number. The screen should appear as shown. Press ENTER to exit the Servo Reversing Function.

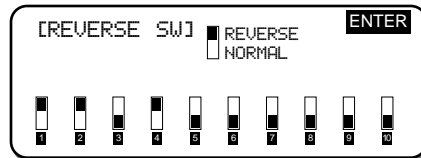

- D) Access the Travel Adjust Function (Code 12) and adjust the servo travel values as shown. Please note that the required travel values will vary based on the type of servo selected. Press ENTER to exit the Travel Adjust Function.

Digital Servos/Super Servos

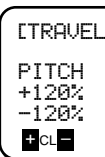
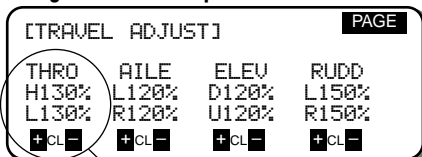

Standard Servos

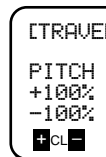
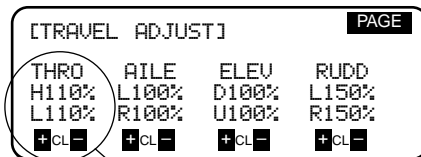

Note: The travel values shown for the rudder function are for use with Piezo type gyros, like the JR NEJ-900, NEJ-400, NEJ-450, or NEJ-3000 type gyros. If a conventional mechanical type gyro is used (JR 120, 130 etc.), then the travel value of the rudder channel will need to be reduced to approximately 100%.

2. JR XP8103/XP8103DT SYSTEMS

The following activation and set-up procedure should be used for all JR XP8103 and XP8103DT (Digital Trim) systems.

Note: Some early XP8103 systems will require the activation of the CCPM software through the Horizon Service Center. It's easy to identify if your system has the CCPM function activated by identifying if the "SWASH TYP" function appears in the System Mode as shown in Section A below. Please refer to Section A to access the System Mode.

Prior to activating the CCPM function, it is first suggested that the Data Reset Function be performed to reset the desired model number to be used back to the factory default settings.

Caution: Prior to performing the Data Reset function, it will be necessary to select the desired model number to be used.

A) Press the UP and DOWN keys simultaneously while turning the power switch on to enter the System Mode. Next, press the UP or DOWN keys to move the cursor to the Model Select Function. Press the UP and DOWN keys simultaneously to enter the Model Select Function. Select the desired model number to be used, then press the CLEAR key to reset the current model to the factory default settings. Press the UP and DOWN keys simultaneously to exit the Model Select Function.

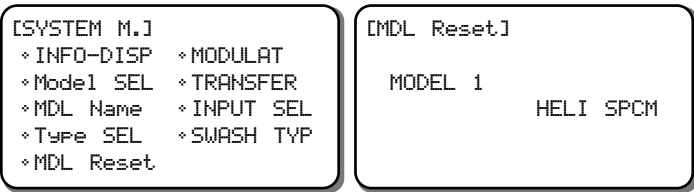

B) Press the UP or DOWN keys to move the cursor to the SWASH TYPE Function, then press the UP and DOWN keys simultaneously to access the Swashplate Type Function.

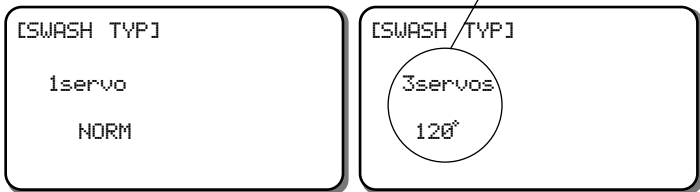

Note: If the Swashplate Type Function is not present, it can be activated by the Horizon Service Center. Please call for details.

Press the UP or DOWN keys until 3 servo 120° appears on the screen. Press the UP and DOWN keys simultaneously two times to exit the Swashplate Type Function and the System Mode.

C) Turn the power switch on, then press the UP and DOWN keys simultaneously to enter the Function Mode. Press the UP key until Swash Mix appears on the screen. Once this has been completed, it will be necessary to change the value of the Pitch Function from the factory default setting of 60, to a value of -50 using the + and - keys.

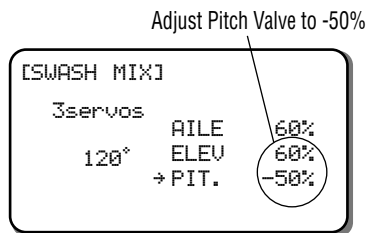

D) Press the UP key until Rev. Sw. (Servo Reversing) appears on the screen. Next, reverse Channels 1, 2, and 4 by moving the cursor with the CH key, then pressing the + or - keys.

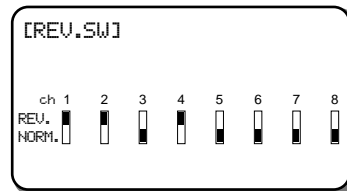

E) Press the UP key until TRVL. ADJ. (Travel Adjust) appears on the screen. Adjust the values as shown using the channel key to move the cursor, and the + and - keys to set the value. Press the SEL KEY to access the pitch channel values and set as indicated. Please note that the required travel values will vary based on the type of servo selected. Please also note that the throttle travel values may vary based on the type of engine used. This value can be fine tuned once the throttle linkage has been installed.

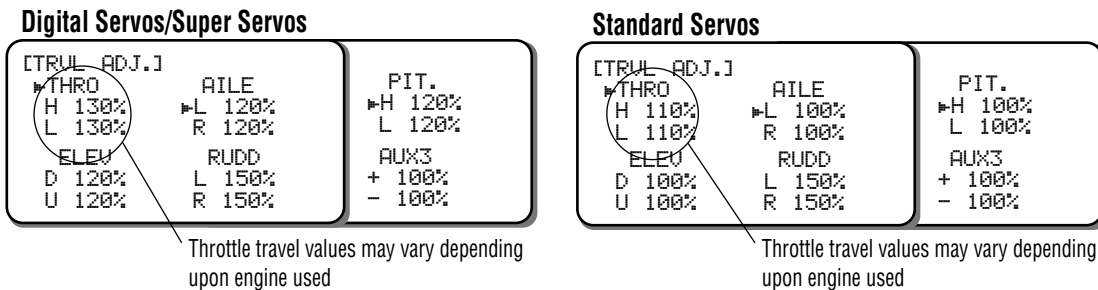

Note: The travel values shown for the rudder function are for use with Piezo type gyros, like the JR NEJ-900, NEJ-400, NEJ-450, and NEJ-3000 type gyros. If a conventional mechanical type gyro is used (JR 120, 130, etc), then the travel values of the rudder channel will need to be reduced to approximately 100%.

3. JR XP652 SYSTEMS

The following activation and set-up procedure should be used for all JR XP652 systems. Please note that the XF622 and XP642 6 channel systems **Do Not** have the required CCPM software, and therefore cannot be activated by the Horizon Service Center.

Prior to activating the CCPM function, it is first suggested that the Data Reset Function be performed to reset the desired model number to be used back to the factory default settings.

Caution: Prior to performing the Data Reset Function, it will be necessary to select the desired model number to be used.

- A) Press the MODE and CHANNEL Keys simultaneously while turning the power switch on to enter the System Mode. Next, press the CHANNEL key until MDL (Model Select) appears on the screen, and choose the desired model number to be used.
- B) Press the MODE key until RST (Data Reset) appears on the screen. Press the + and - keys simultaneously to reset the current model. A high pitched beep will indicate that the reset was successful. Press the MODE and CHANNEL keys simultaneously to exit the system mode.
- C) With the power switch still on, press the MODE and CHANNEL keys simultaneously to enter the Function Mode. Press the MODE key until MIX CCP (CCPM mixing) appears on the screen. Press the + or - keys to activate the CCPM function. Mix CP2 should appear on the screen. Next, press the CHANNEL key until MIX CP6 appears on the screen. It will be necessary to change the value of CP6 (Channel 6, Aux1) from +60 to -50 using the - key.

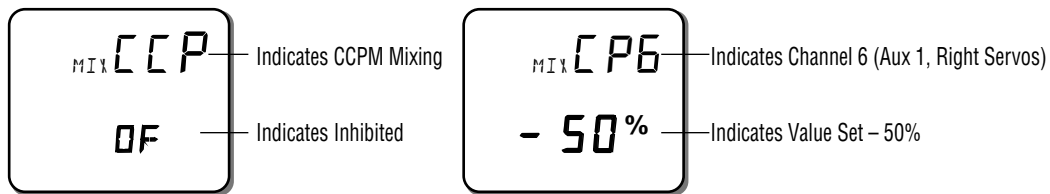
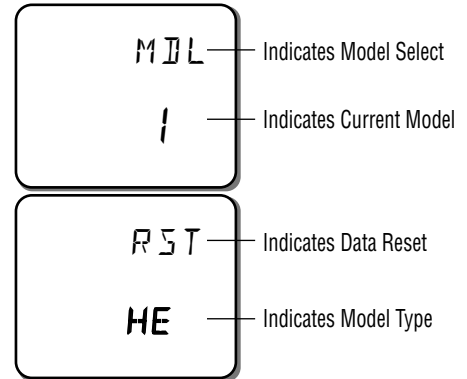

- D) Press the MODE key until the servo reversing screen appears on the screen. Next, reverse the Throttle (THR), Aileron (AIL) and Rudder (RUD) channels by pressing the CHANNEL key to select the desired channel, and then the + or - keys to set the servo direction.



- E) Press the MODE key until TRV ADJ (Travel Adjust) appears on the screen, and adjust the travel values as shown by pressing the CHANNEL key to select the desired channel, and then the + or - key to set the desired travel value. Press the MODE and CHANNEL keys simultaneously, or turn the power switch off, to exit the Function Mode. Please note that the throttle travel values may vary based upon the type of engine used. This value can be fine tuned once the throttle linkage has been installed.

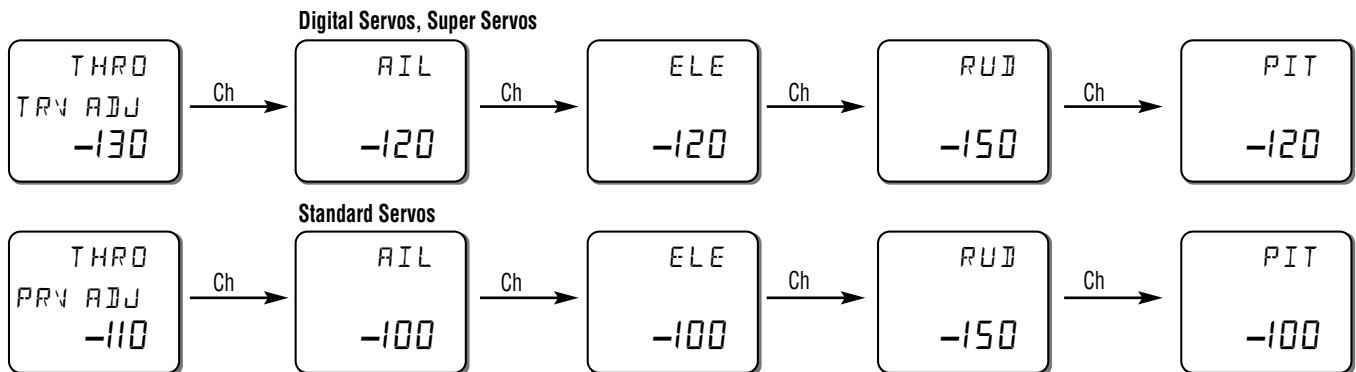

Note: The travel values shown for the rudder function are for use with Piezo gyros, like the JR NEJ-900, NEJ-400, NEJ-450, or NEJ-3000 type gyros. If a conventional mechanical type gyro is used (JR 120, 130, etc.), then the travel values of the rudder will need to be reduced to approximately 100%.

A. TRAVEL ADJUST

It is extremely important that the travel adjustment values for the 3 CCPM servos (Aileron, Elevator, AUX 1) be initially set to exactly the same travel value. If the travel value is not similar for each servo, it will create unwanted pitching and rolling of the swashplate during collective pitch inputs. The travel values for each servo will be adjusted in steps 7.5 and 7.6 to remove any minor pitch and roll coupling during pitch, roll, and collective movements.

Minor travel value adjustments are necessary due to slight variations in servo travel and centering. Although the three servos may appear to travel at the same amounts in each direction, in reality the servos can vary slightly. This variation is more common in analog type servos. If JR's new Digital Servos are used, the travel adjustment values will generally not need to be altered.

B. SERVO REVERSING

It is also extremely important that the servo reversing directions for the three CCPM servos (Aileron, Elevator, AUX 1) be set as indicated in the previous radio programming steps. If one or more servos is not set to the correct direction, the CCPM function will be out of synchronization, and the three control functions (Aileron, Elevator, Collective) will not move properly. In the event that a control surface is working in the wrong direction, the control function can only be reversed by changing the desired CCPM value for that function from a + to a - value, or vice versa.

Example: If, when you increase the collective pitch, the pitch of the main blades actually decreases, it will be necessary to access the CCPM function and change the travel value for this function from + to -, or - to +. This will reverse the direction of the collective pitch function without affecting the movement of the aileron and elevator functions.



To reverse the direction of a CCPM control function it's necessary to change the value from + to -, or - to + as needed.

C. CCPM SERVO CONNECTIONS

The JR 120° CCPM system requires the use of three servos to operate, Aileron, Elevator, and AUX 1(Pitch). The labeling of these servos can become quite confusing because with the CCPM function, the three servos no longer work independently, but rather as a team, and their functions are now combined. For this reason, we will refer to the three servos in the following manner:

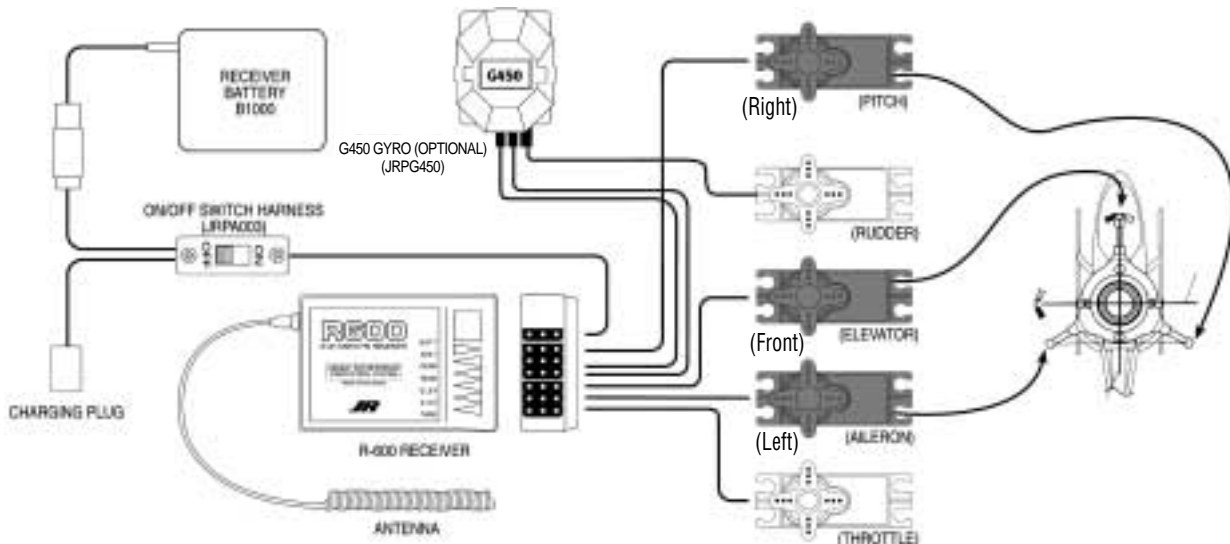

- Aileron Servo:** We will refer to this servo as the "Left" servo. The channel number for this servo when using a JR radio is CH2.
- Elevator Servo:** We will refer to this servo as the "Front" servo. The channel number for this servo when using a JR radio is CH3.
- AUX 1 (Pitch) Servo:** We will refer to this servo as the "Right" servo. The channel number for this servo when using a JR radio is CH6.

Please refer to the CCPM connections chart below for clarification. For Non-JR radios, please consult your radio instructions for proper connection.



7-1

SERVO ARM PREPARATION AND INSTALLATION

-  3 pcs
2x10mm Flat Head Screw
-  3 pcs
Steel Joint Ball
-  3 pcs
2mm Hex Nut

Use Blue Threadlock

It will be necessary to prepare three servo arms as shown in the diagram below. Prior to assembling the servo arms, the servos should be centered as indicated below, and the servo arms test fitted to the servo to insure that the arms will attach to the servo as indicated. Since the JR servo arm spline uses an odd number of teeth, it is sometimes possible to rotate the servo arm 180° to achieve a more correct positioning.

Once the best direction for the servo arm has been decided, mark the servo arm with the servo it is to be connected to (F, R, or L), as well as the side of the servo arm that needs to be removed.

It is **very** important that a heavy-duty type servo arm be used with the control ball location placed at exactly 20mm as shown. For JR radio users, we recommend the JRPA215 heavy-duty Servo Arms for this use. If a control ball position other than the specified 20mm is used, this will create an adverse affect as to the travel of the swashplate, as well as unwanted control differential and interaction.

Prior to attaching the servo arm to the servo, it will be necessary to first turn on the radio system to center each of the three CCPM servos. It is important that the radio's collective pitch stick be set at the center position. If your radio is equipped with a hover pitch knob, please check to make sure that this knob is also in the center position at this time.

Connect the three servo arms to the three CCPM servos as shown. It is important that the servo arms be positioned parallel to the servos as shown. If the servo arm is not parallel as shown, minor centering adjustments can be made using the radio's Sub-Trim Function. Please refer to Section 7-2 for more information.

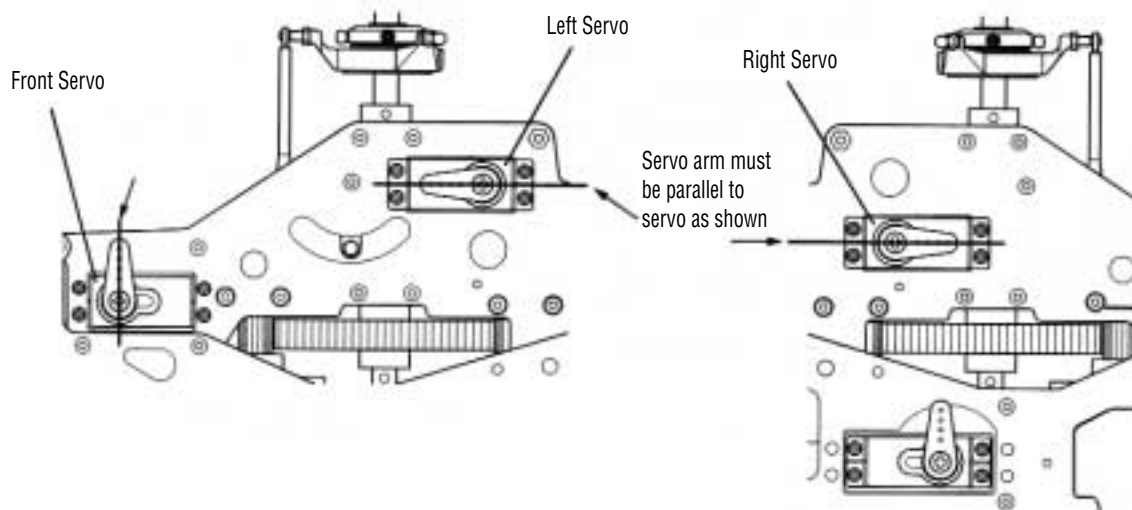
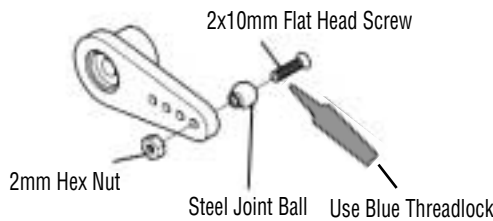
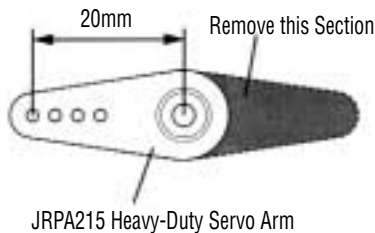

7-2

CCPM SERVO CENTERING WITH THE SUB-TRIM FUNCTION

As mentioned in the previous step, it may be necessary to make minor servo centering adjustments with the use of the Sub-Trim Function to achieve the desired servo arm positions. Please refer to your particular radio's section as listed below, or consult your radio instruction manual for more information.

JR PCM10, 10S, 10SX, 10SXII, 10X SYSTEMS

- 1) Enter the Sub-Trim Function (Code 15)
- 2) Adjust the Left (aileron), Right (AUX 1) and Front (elevator) servos as needed until the servo arm is exactly parallel to the servo as shown when the collective stick is in the center position. It will be necessary to press the PAGE button to access the Right servo (AUX 1) sub-trim value.
- 3) Press ENTER to exit the Sub-Trim Function.

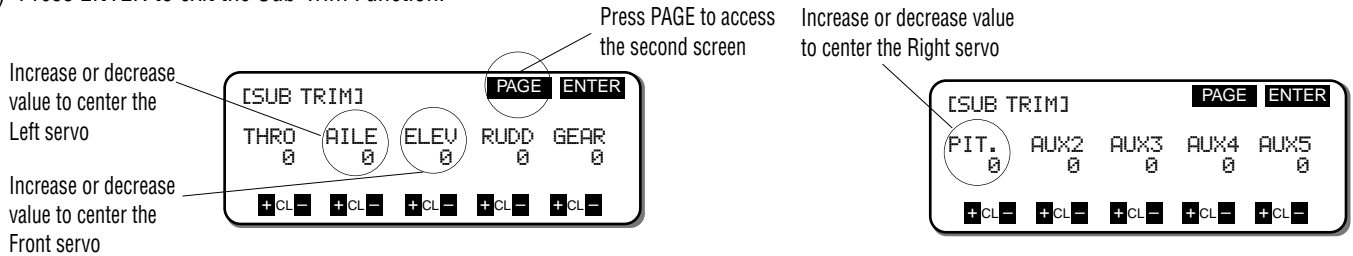

XP8103, XP8103 WITH DIGITAL TRIMS

- 1) With the radio power switch on, press the UP and DOWN keys simultaneously to enter the Function Mode.
- 2) Press the UP key until Sub Trim appears on the screen.
- 3) Adjust the Left (aileron), Right (AUX 1), and Front (elevator) servos as needed until the servo arm is exactly parallel to the servo as shown when the collective stick is in the center position. It will be necessary to press the SEL key once to access the Right servo (AUX 1) sub-trim.
- 4) Press the UP and DOWN keys simultaneously to exit the Function Mode.

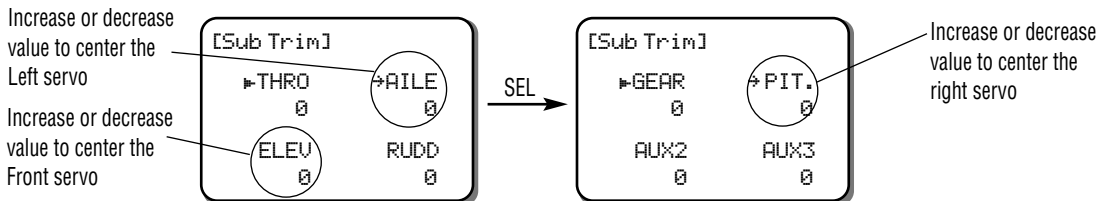

XP652 SYSTEM

- 1) With the radio power switch on, press the MODE and CHANNEL keys simultaneously to enter the Function mode.
- 2) Press the MODE key until SB-TRIM (sub-trim) appears on the screen.
- 3) Adjust the Left (aileron), Right (AUX 1), and Front (elevator) servos as needed until the servo arm is exactly parallel to the servo as shown when the collective stick is in the center position. It will be necessary to press the CHANNEL key to access the necessary channels to be adjusted.
- 4) Press the MODE and CHANNEL keys simultaneously to exit the Function Mode.

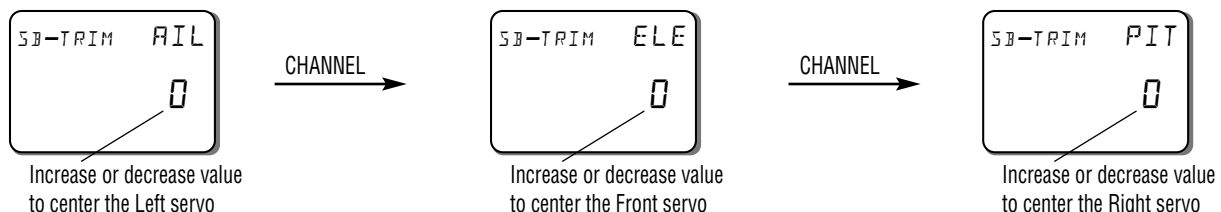

7-3

CCPM LINKAGE CONNECTIONS

Assemble and adjust the three CCPM servo linkages as shown below. It is important the the exact distances specified below be maintained for each linkage as this is critical to the alignment and neutral position of the swashplate. Please also note the direction of the ball links as shown by the JR Propo name imprinted on each ball link. The JR Propo name is imprinted on the front of each ball link. When attaching the control rods, it is important to make sure that the JR Propo name faces outward as the links are attached to the control balls.

Please also note that when attaching control linkages B and C, it will be necessary to rotate the link that attaches to the swashplate slightly so that it is parallel to the rear mounting surface of the ball link. This will allow the control linkage to rotate slightly on the two control balls.

Is is also recommended that the JR Ball Link Sizing Tool be used to size the ball links for a proper fit prior to attachment.

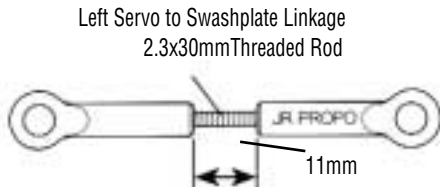
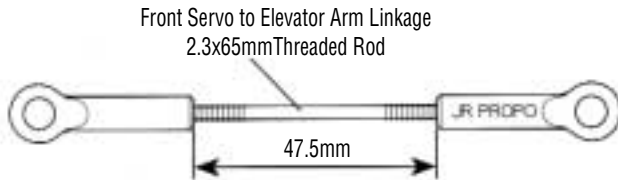

Option: For smooth operation, pre-size the ball links with the JR Ball Link Sizing Tool prior to attachment.

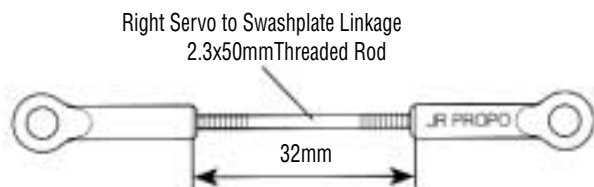
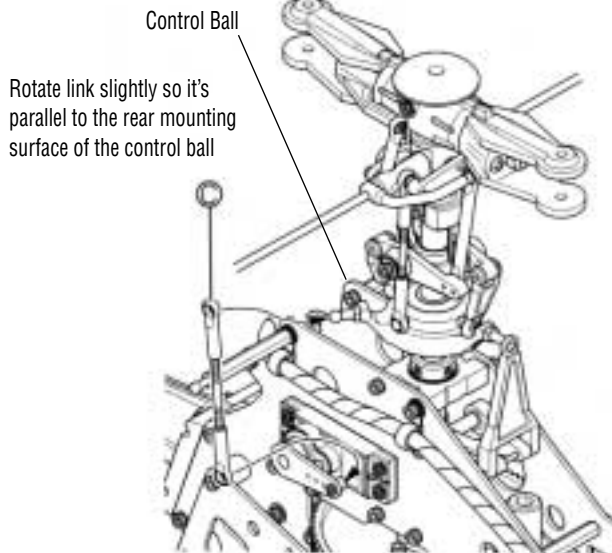
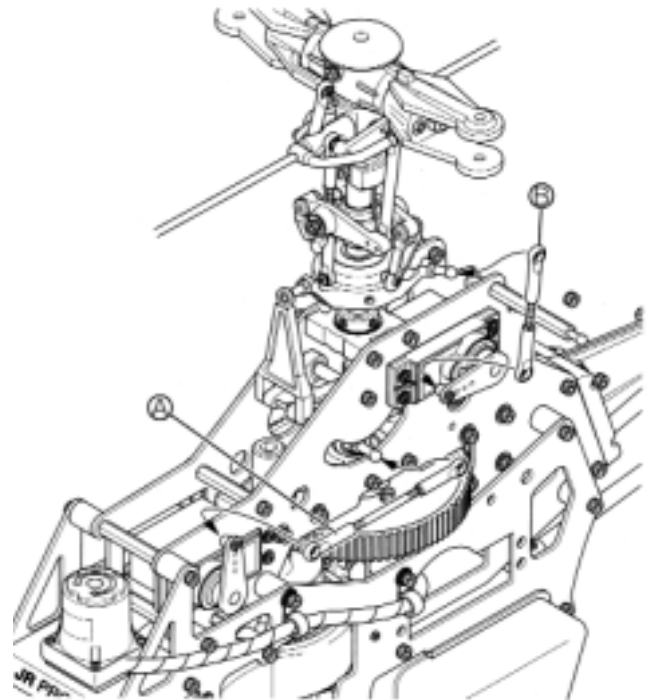

7-4

CHECKING THE SWASHPLATE FOR LEVEL

After the three control linkages have been attached to the swashplate, it will be necessary to check the swashplate to insure that it is level. To do this, turn on the radio system and place the collective stick in the center position as before. Next, check to make sure that all trim levers and knobs are also in their center position.

Check to insure that the servo arms are parallel to the servos as adjusted in the previous step. If the servos are not parallel, please refer to the Sub-Trim Section on page 42 and re-adjust as necessary.

Once it's determined that the servo arms are parallel to the servos as required, it will now be necessary to check the swashplate to insure that it is also level, or neutral in this position.

It is suggested that the swashplate first be checked from the rear of the model to insure that it's level from left to right. If the swashplate is not level as compared to the frame of the model, adjust either the Left or Right servo control rod as needed. To determine which rod needs adjustment, it may be helpful to view the swashplate from the left and right side view of the model to determine which side is high or low.

Once this Left to Right adjustment is completed, it will now be necessary to check the fore/aft position of the swashplate to insure that it is also level on this axis. If the swashplate is not level in the fore/aft axis, it is suggested that the adjustment be made to the Front servo control linkage as needed.

If you are unsure as to which linkage needs adjustment or are having difficulty obtaining the correct adjustment, please check the length of each control rod to insure that it is adjusted to the correct length as outlined in Step 7-3.

Note: If care was taken in the linkage assembly in Step 7-3, little or no adjustment should be required in this step. Only minor adjustments should be made to the lengths of the control linkages at this time. Any major adjustments indicates either incorrect linkage lengths or incorrect servo arm positioning. If the control linkage lengths are altered from the recommended lengths more that 1 or 2 turns, this will have a great effect on the range and settings of the collective pitch in later steps.

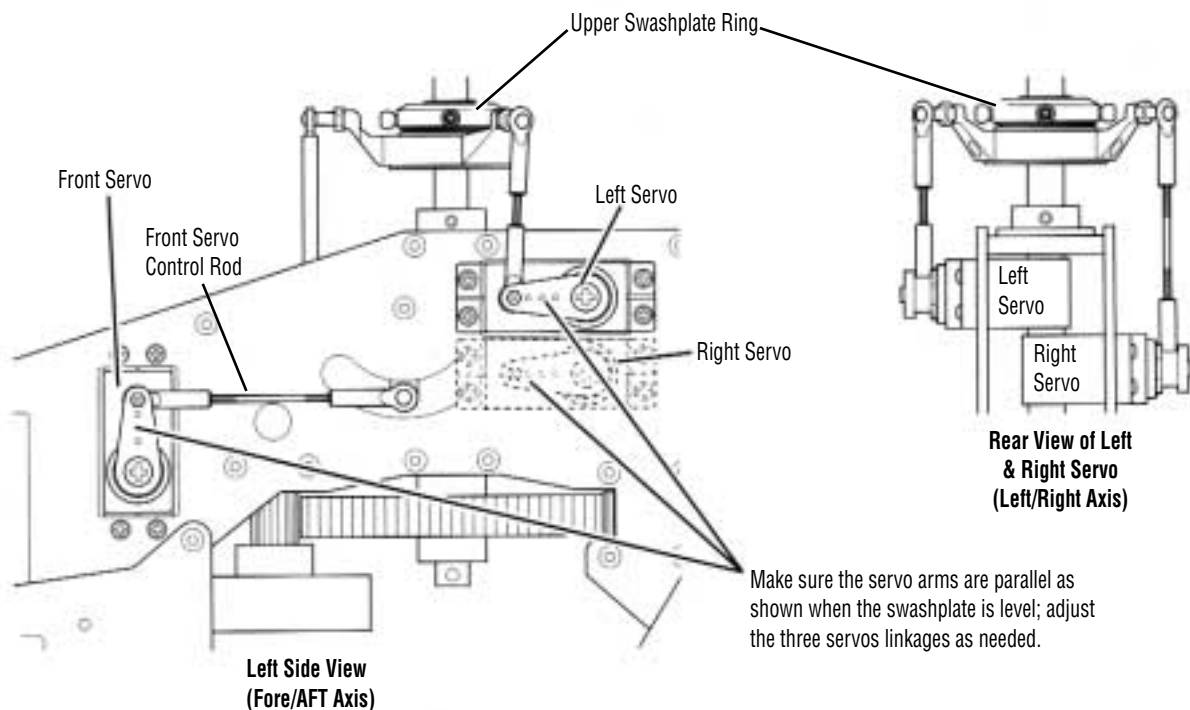

7-5

PITCH-TO-AILERON MIXING ADJUSTMENT WITH TRAVEL ADJUST

As mentioned previously, it is very possible that the travel of each servo varies slightly, which can cause the swashplate to be tilted to the left or right when the collective is moved to the extreme high and low pitch positions. This condition is generally more common when standard type servos are used. If JR Digital Servos are used, the adjustment required is generally very small, if any. These variations in travel can be corrected by altering the travel value of each servo slightly through the Travel Adjustment Function.

To check the Pitch-to-Aileron Mixing, it will first be necessary to position the collective stick in the center position as in the previous steps. Next, move the collective stick from the center position to the high pitch position while viewing the swashplate from the rear of the model as shown in the diagram below. While moving the swashplate, look for any tendency for the swashplate to roll to the left or right as it reaches the high pitch position. Repeat this procedure several times to be sure that your observations are correct. If no rolling tendency is found, it will now be necessary to repeat this procedure from the center collective stick position to full low pitch. If no rolling tendency is found, proceed to Step 7-6.

In our example, we have shown that the swashplate has been tilted to the right as the collective has been increased to full pitch. This would indicate that the Left servo's maximum travel is greater than the Right servo's maximum travel.

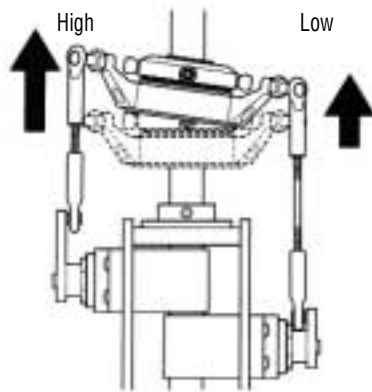

AILE= Left Servo
ELEV= Front Servo
AUX1= Right Servo

View is shown from the rear of the model. Notice how in this example, the swashplate has tilted to the right as the collective has moved from center to full high pitch position.

In this condition, we would suggest that the travel value for the Left servo be reduced slightly (5–10%). Repeat the procedure above. If the same condition occurs, but to a lesser degree, then the travel value of the Right servo should be increased slightly and retest. In most cases, it will require only the adjustment of the Left or Right servo to correct this situation.

For information on the Travel Adjustment Function, please refer to page 40, or your radio instruction manual for details.

Once this condition has been corrected, repeat this procedure for the center to low collective pitch position and adjust as needed.

As mentioned in the previous step, the total travel of each servo can vary slightly, which can also cause the swashplate to be tilted fore and aft when the collective is moved to the extreme high and low pitch positions. This situation can also be corrected if necessary through the use of the Travel Adjustment Function.

To check Pitch-to-Elevator Mixing, it will first be necessary to position the collective stick in the center position as in the previous steps. Next, move the collective stick from the center to the high pitch position while viewing the swashplate from the left side of the model. While moving the swashplate, look for any tendencies for the swashplate to tilt fore or aft as it reaches the high pitch positions. Repeat this procedure several times to be sure that your observations are correct. If no fore or aft tilting tendencies are found, it will now be necessary to repeat this procedure from the center collective stick position to full low pitch. If no tilting tendency is found, proceed to the next step.

In our example, we have shown that the swashplate has been tilted forward as the collective has been increased to full high pitch. This would indicate that the Front servo's maximum travel is now more than that of the two rear servos (Left and Right).

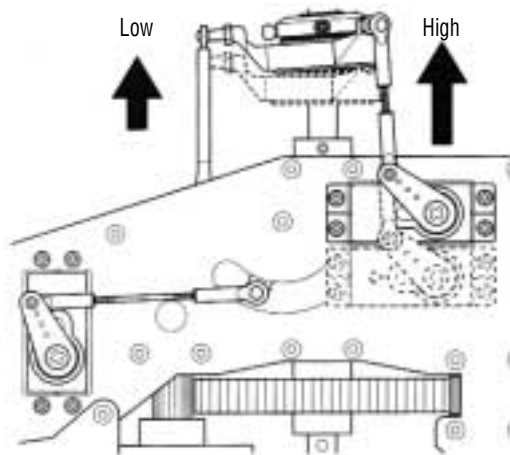

View is shown from the left side of the model. Notice how in this example the swashplate has tilted forward as the collective has moved from the center to the full high pitch position.

In this condition, we would suggest that the travel value for the Front servo be increased slightly (5–10%). Repeat the above procedure and increase the value as needed until the tilting tendency is eliminated.



For information on the Travel Adjustment Function, please refer to page 40, or your radio instruction manual for details.

Once this condition has been corrected, repeat this procedure for the center to low collective pitch position and adjust as needed.

Note: It is very important that during this step, only the travel value for the front servo (elevator) be adjusted to correct any pitch-to-elevator tendencies. If the travel value of the Left or Right servo changes, this will affect the pitch-to-aileron tendencies corrected in the previous step. If you feel that readjustment of the Left and Right servo travel is necessary, then it is suggested that the travel for each servo be increased or decreased at the same amount, and the pitch-to-aileron procedure be re-tested.

7-7

TAIL CONTROL ROD SERVO CONNECTION

-  1 pc
2x8mm Flat Head Screw
-  1 pc
Steel Joint Ball
-  1 pc
2mm Hex Nut

Use Blue Threadlock

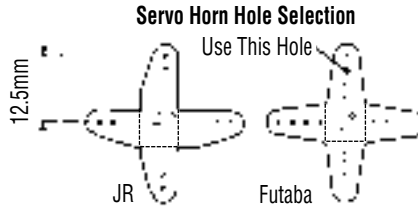
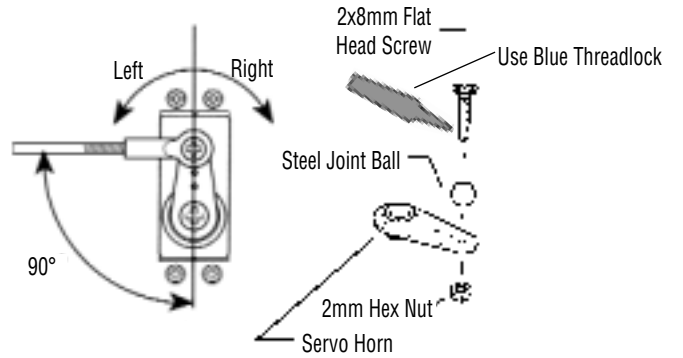
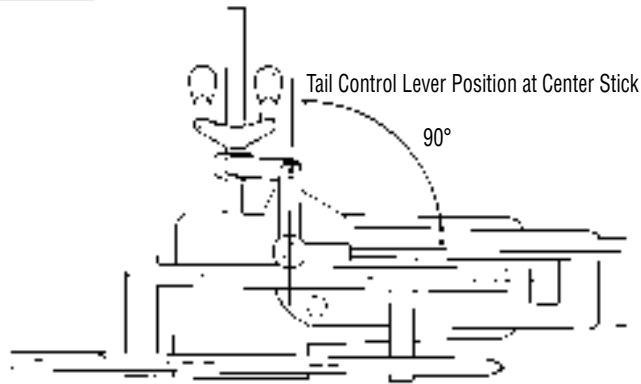

Note: Make certain that the Tail Rotor Servo is in the neutral or hover position before securing the Servo Horn to the Servo.



An Important Note: Check to insure the Tail Control Rod can slide through the Tail Control Rod Guides smoothly before connecting it to the Servo. If resistance is felt, rotate the Tail Control Rod Guides slightly until the Control Rod slides smoothly.

7-8

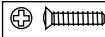
THROTTLE LINKAGE INSTALLATION

- 1 pc
2x8mm Flat Head Screw
- 1 pc
Steel Joint Ball
- 1 pc
2mm Hex Nut



Note: Make sure that the Throttle Trim is in the low position before attaching the Servo Horn.

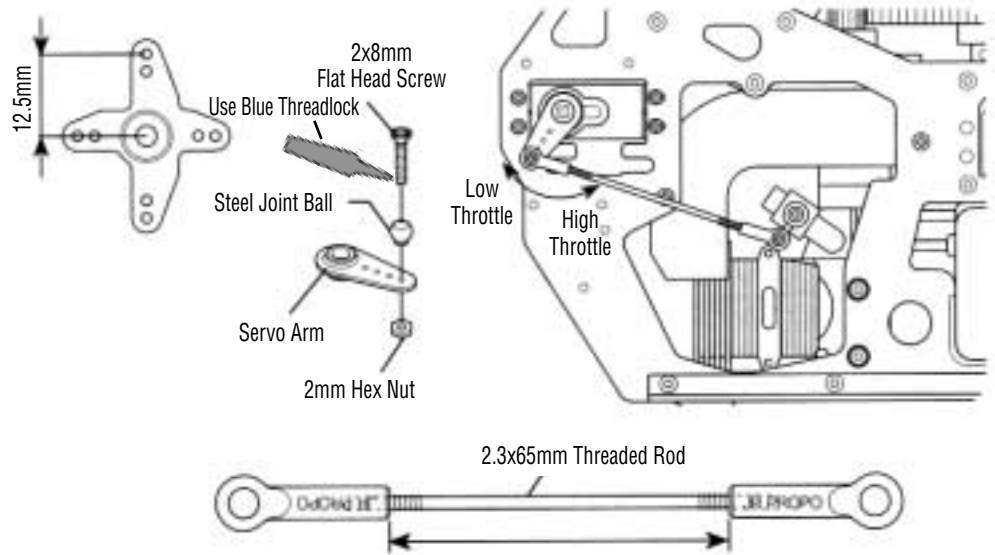

SERVO HORN SELECTION/LINKAGE ADJUSTMENTS

JR System/Webra .35 Engine or MDS .38 Heli Engine

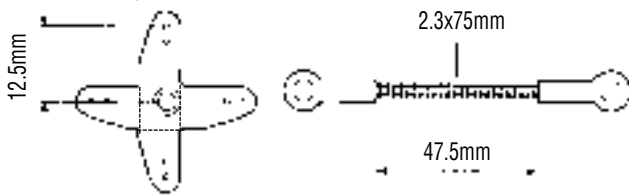

JR System/O.S. .32SX-H Engine

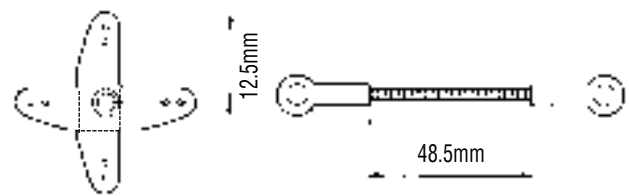

Futaba System/Webra .35 Engine or MDS 38 Heli Engine

Be sure to remove the excess servo horn arms as shown. Secure the Servo Horn using the Servo Horn Screw.

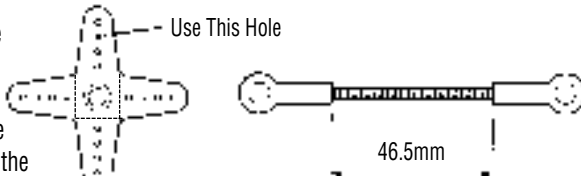

Futaba System/O.S. .32SX-H Engine

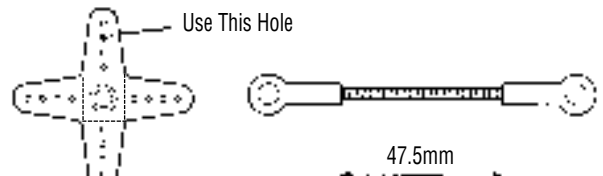

THROTTLE ARM/SERVO HORN POSITIONS

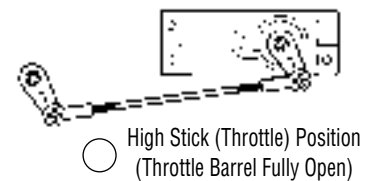
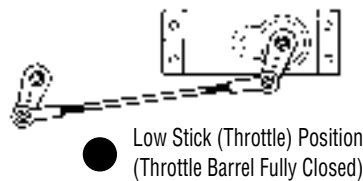
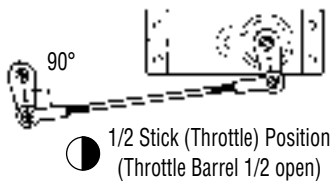

*To avoid differential throttle travel, make certain both the throttle arm and the servo horn are positioned as shown in the above diagrams.



To achieve the correct position of the throttle/servo arm, it may be necessary to re-position the throttle arm on the carburetor. It may also be necessary to adjust the length of the throttle linkage slightly to achieve full open and closed positions of the carburetor.

It is also possible to increase/reduce the travel of the throttle servo through

the Travel Adjust Function found in most computer radio systems. If this function is used, make sure the values for the high and low positions remain equal (same value for high/low). If these values are not equal, this will create a differential, or uneven movement of the throttle, making rotor rpm adjustment and fine tuning more difficult.

8-1

BODY ASSEMBLY/CANOPY ATTACHMENT

4 pcs
8 pcs
4 pcs
8 pcs



Note: It will be necessary to trim away the unwanted plastic off the canopy and side window areas using a hobby knife.

* After trimming, attach the canopy to the body temporarily with tape. Next, drill five 1/16" holes through both the canopy and the body and secure using the 2.3x8mm screws provided.

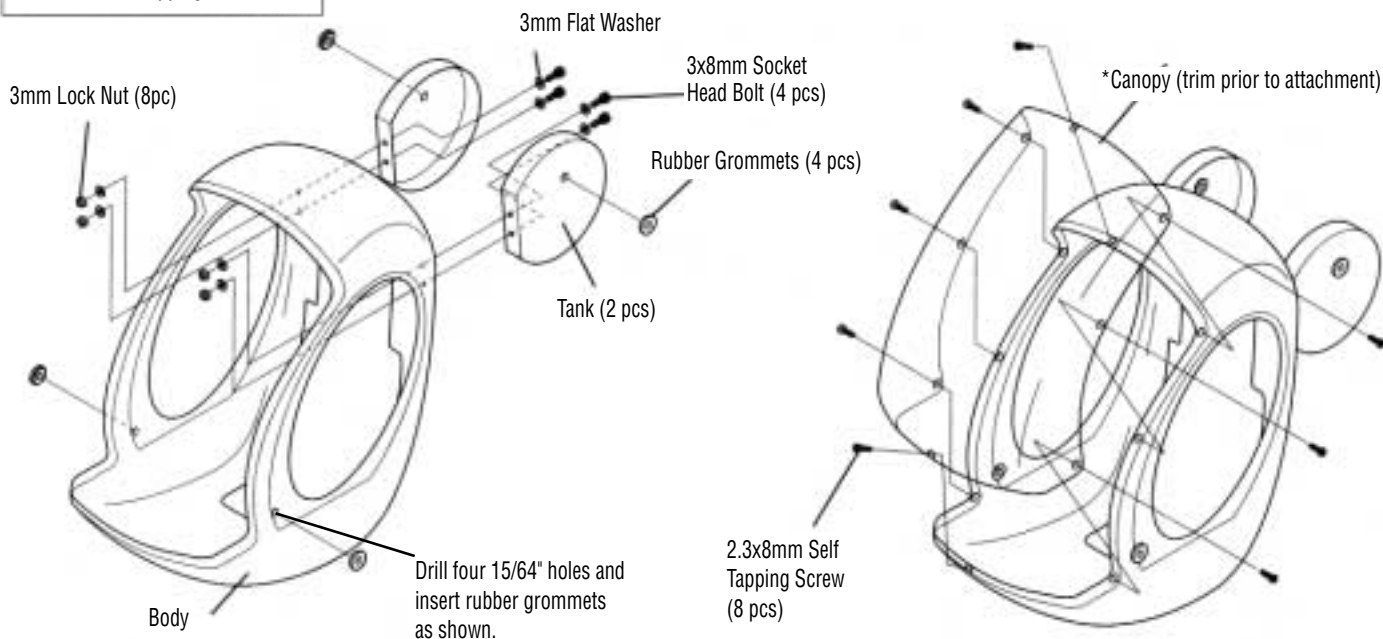

8-2

BODY ATTACHMENT

Slide the completed body over the mechanics and secure through the four canopy mount standoffs as shown.

Note: Check to insure that the body does not come contact with any portion of the Main Frame, Muffler, Servo/Servo Horns, etc. Trim for clearance if necessary.

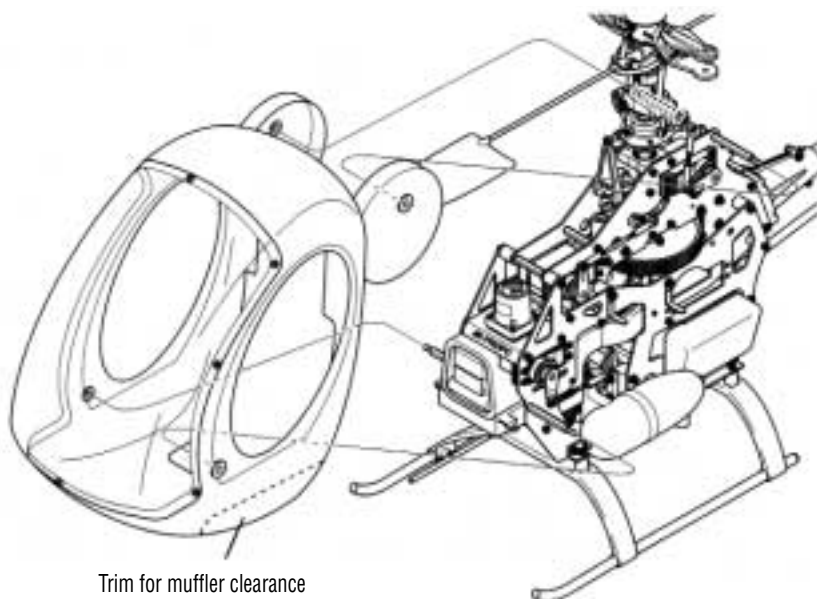

Ergo 30 CEFM

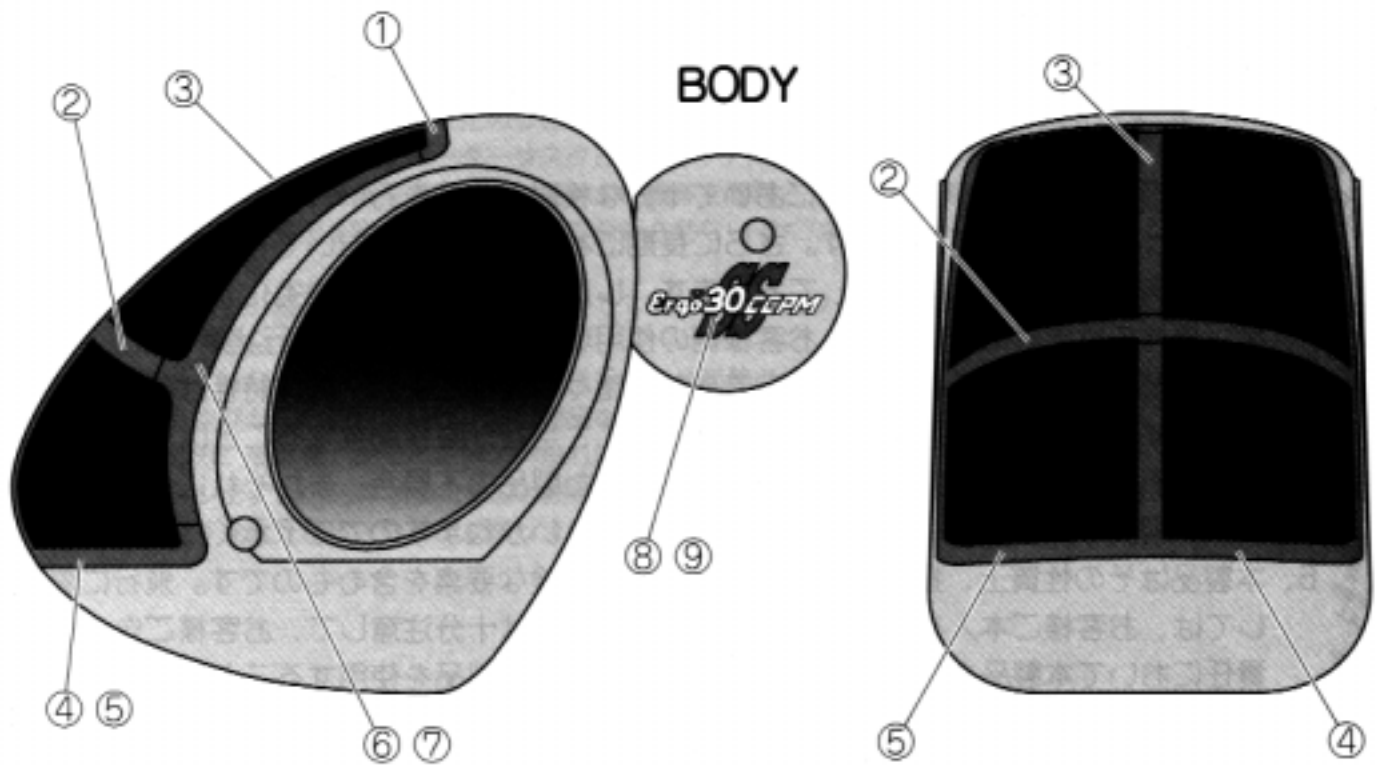
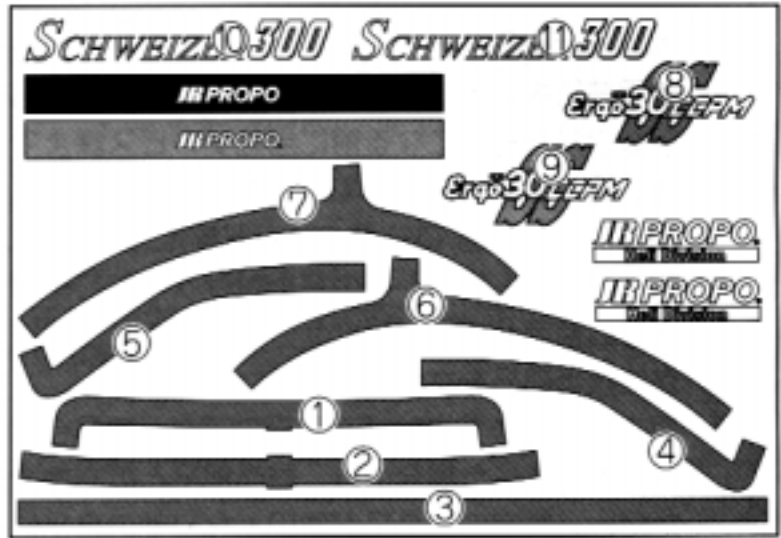

8-3

MAIN ROTOR BLADE BALANCING

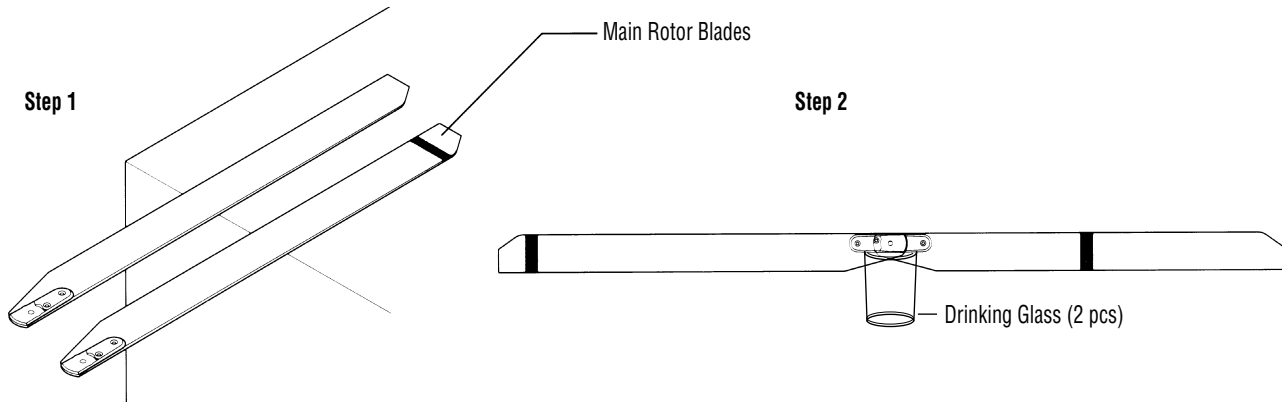

Spanwise C.G. Balancing

Place each rotor blade on a sharp edge of a table as shown and adjust so each rotor blade “teeters” on the edge of the table. If the blades are correctly balanced, they should be at an equal distance to the edge of the table. If they are not, apply tape to the center of the light or short blade until equal distance can be achieved.

Final Static Balancing

To static balance the main rotor blades, either attach each blade to a “seesaw” type blade balancer (RVO1001) or bolt each of the two blades together through the blade mounting holes shown and suspend this unit between two drinking glasses. Add blade tracking tape (from decal sheet) to the tip of the light or high blade until they each become level to the table surface.

8-4

MAIN ROTOR BLADE ATTACHMENT

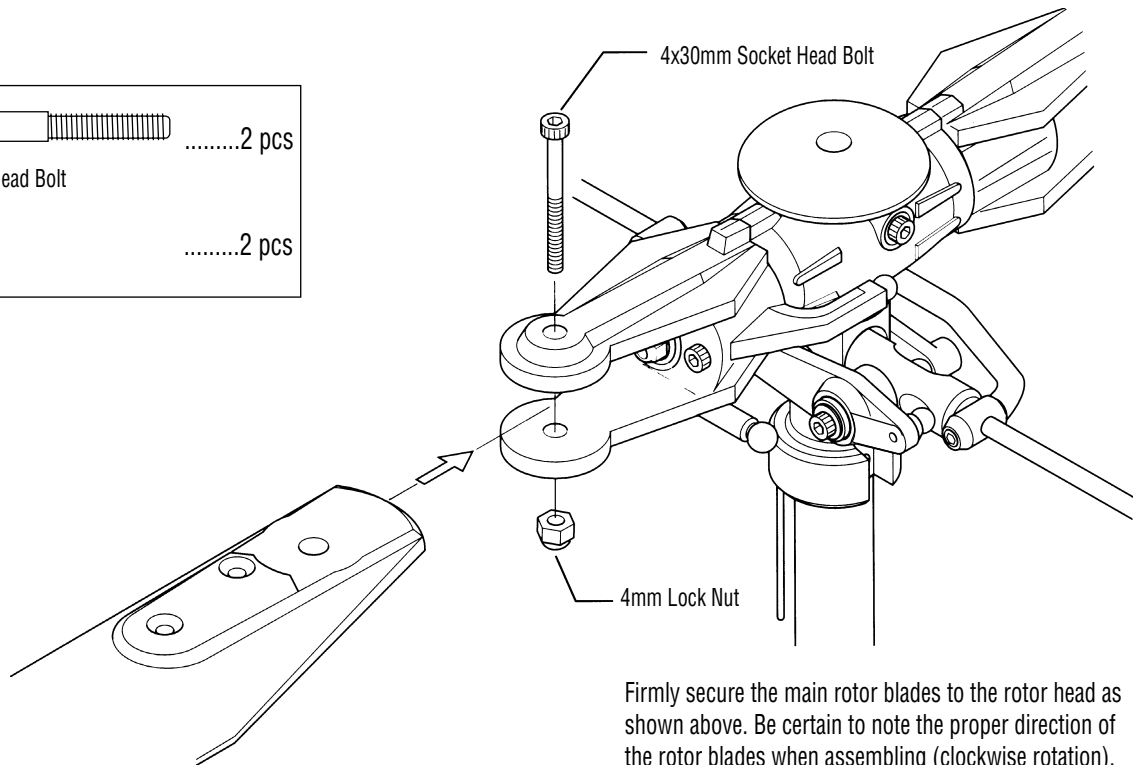
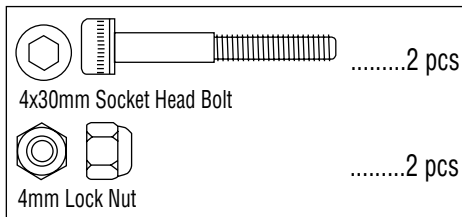

Firmly secure the main rotor blades to the rotor head as shown above. Be certain to note the proper direction of the rotor blades when assembling (clockwise rotation). Main blades should be tightened so they can pivot when moderate pressure is applied. Do not allow the main blades to swing freely within the main blade holders.

Now that the radio system is completely installed into the helicopter, it is necessary to check and adjust the following:

1. Servo Direction (Servo Reversing)

Check to insure that all servos have been set to the correct direction as shown in Steps 7-1 to 7-5.

2. Dual Rates

It is suggested that for initial flights the Dual Rate Function values be set as follows:

- 0 Position (low rate): 60%
- 1 Position (high rate): 100%

3. Exponential Settings

It is suggested that the exponential rate settings remain in the 0 value position until the initial test flights. After initial flights, adjust the exponential values to achieve the desired control feel.

4. Sub-Trim Settings

It is suggested that the correct neutral settings be achieved without the use of the sub-trim feature. If sub-trim is used for final flight adjustments, it is suggested that the sub-trim values not exceed 10. If the sub-trim values are greater, readjust the control linkages and reset the sub-trims to 0.

6. Pitch/Throttle Curve Adjustment

It is very important that the throttle and pitch curves are adjusted properly to achieve the best performance from your helicopter. When properly adjusted, the main rotor head rpm should remain consistent throughout all maneuvers and throttle stick positions. A constant rpm will also help to improve the effectiveness and accuracy of the tail rotor and gyro systems.

A. Pitch Curve Adjustment

It will now be necessary to adjust the main rotor blade pitch to match the settings shown in the chart below. A Main Rotor Blade Pitch Gauge (sold separately) will be necessary for this procedure. Prior to setting the main rotor blade pitch, it will be necessary to first set the required blade pitch at 1/2 (center) stick. Turn the system on and set the collective pitch stick to the center position as in previous steps. If all linkages are properly adjusted, the swashplate/rotor head system should appear as shown in the diagram below. Please note that at the center pitch position, the seesaw mixing arms located on the rotor head are parallel (level) to the seesaw shaft/flybar assembly.

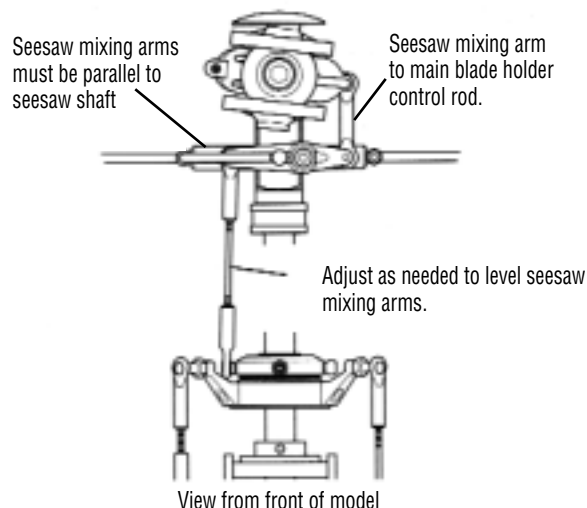

Pitch Range Settings

Flight Mode	Application	Low Pitch (Low Stick)	Hovering Pitch (Half Stick)	High Pitch (High Stick)
N	Hovering	-2°	5°	10°
I	Stunt & Aerobatic Flight	-5°	5°	8.5°
H	AutoRotation	-5°	5°	13°

Pitch Curve Settings

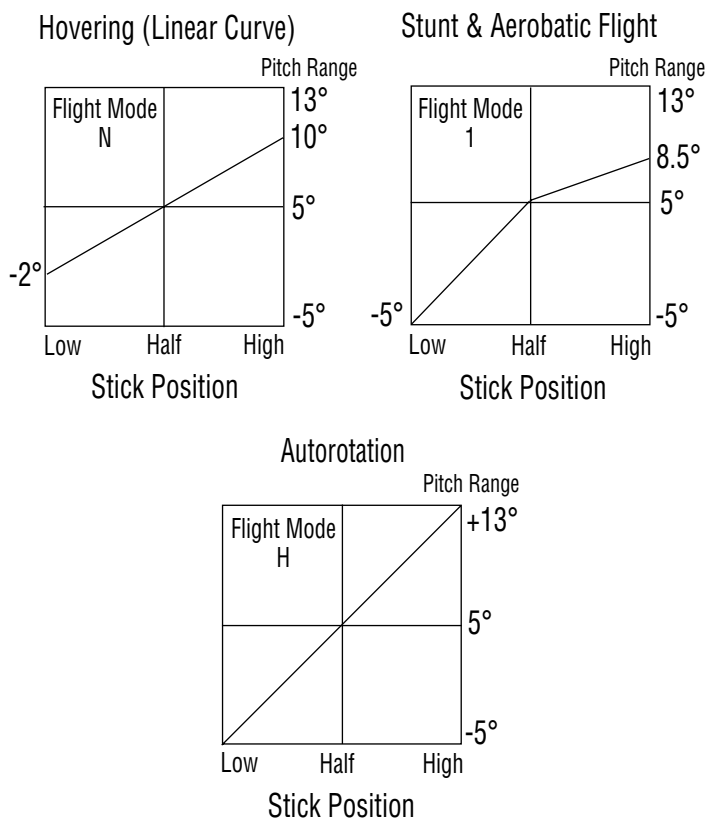

If your seesaw mixing arms are not level as shown, adjust the 2 seesaw arm to swashplate control rods as needed.

Once the position of the seesaw mixing arms have been established, attach a main rotor pitch gauge (sold separately) to one rotor blade and check the current pitch setting. The current pitch should be approximately +5. If the pitch is slightly less or more, this can be adjusted later through the radio's Pitch Curve Function. Attach the pitch gauge to the second main rotor blade and match the pitch at this time.

It will now be necessary to establish the maximum pitch value required for your application prior to adjustment. For example, if you are a beginning pilot, then your maximum negative pitch will be -5, and your maximum positive pitch will be +10. The maximum pitch range that you will require will be +10.

The maximum pitch range mentioned above must be established through the use of the pitch travel value in the CCPM function. As mentioned previously, do not try to establish the maximum pitch curve values through adjustment of the Travel Adjustment Function, as this will alter the pitch-to-aileron, and pitch-to-elevator travel values established in Steps 7-5 and 7-6.

Please refer to the CCPM activation section, page 35-37, for information on how to access the CCPM function.

Once the CCPM function has been activated, set the maximum positive pitch settings as mentioned above. Since the CCPM function does not allow for independent travel settings for positive and negative pitch, it will be necessary to establish the maximum positive pitch, since this is generally the largest degree of pitch in the pitch range. Once the maximum positive pitch range is set, the maximum negative Pitch range can be reduced as needed through the Pitch Curve Function.

Set the main rotor pitch gauge to the desired maximum pitch setting, then increase or decrease the CCPM pitch travel (labeled Pitch or Ch6) as needed until this pitch setting is achieved.

B. Throttle Curve Settings

Below are several examples of possible throttle curves during various flight conditions. Since throttle curves can vary greatly due to engine and muffler combinations, it will be necessary to fine tune and adjust these values during test flights to achieve a constant main rotor rpm.

Hovering (Linear Curve)

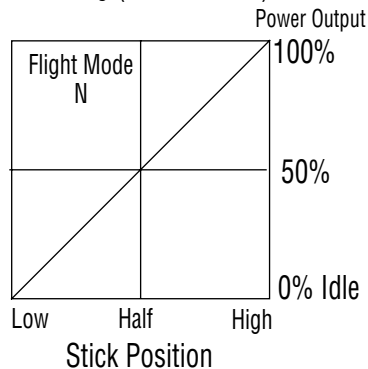

Stunt & Aerobatic Flight

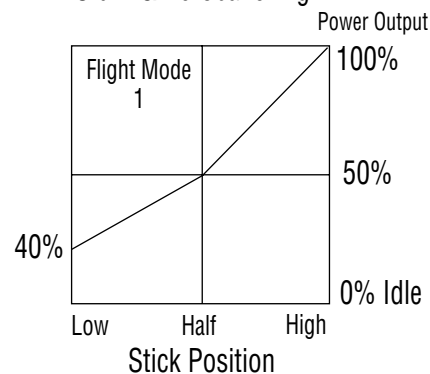

XP652 System



Increase or decrease the value as needed

PCM 10 Series

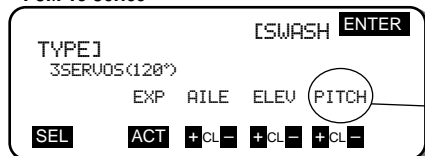

Increase or decrease the value as needed

XP8103 System

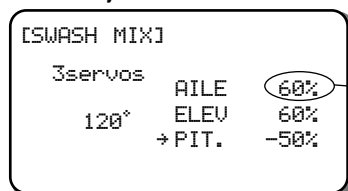

Increase or decrease the value as needed

Once

this procedure has been completed, the positive and negative pitch settings for each flight mode can be adjusted through the radio's Pitch Curve Function. Please refer to your radio's instruction manual for more information.

It will also be necessary to set the correct idle speed of the engine when the Throttle Hold Function is activated.

This idle value is located within the Throttle Hold Function. This will allow the engine to remain at idle when practicing autorotations.

6. Revolution Mixing

It will be necessary to adjust the revolution mixing to properly compensate for the torque of the engine during all flight conditions (except autorotation). Since there are many variables that can alter the value of the revolution mixing (engine, blade pitch, fuel, etc.), it will be necessary to fine tune this function during test flights. The following values are shown only as a starting point toward achieving proper compensation:

**PCM 10 Series radio with NEJ450,
NEJ900 & NEJ3000 Gyros**

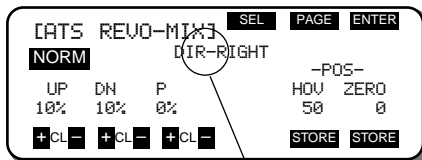

Make certain that the compensation direction is set to "Right."

**PCM 10 Series radio with
NEJ120 & NEJ130 Gyros**

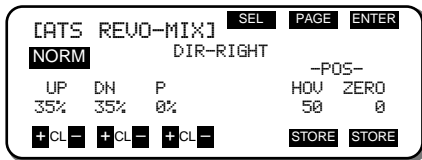

**XP8103 with NEJ450, NEJ900 &
NEJ3000 Gyros**

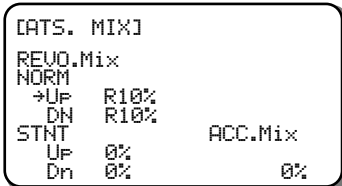

Make sure that the direction is set to R (right)

XP8103 with NEJ120 & NEJ130 Gyros

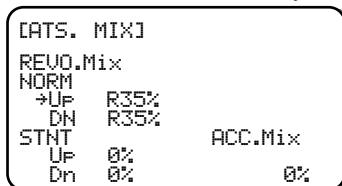

**XP652 with NEJ450,
NEJ900 & NEJ3000 Gyros**

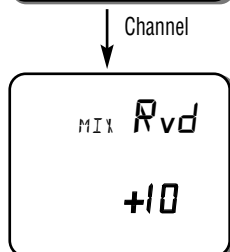
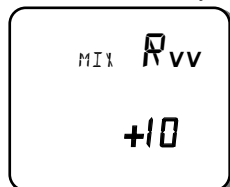

**XP652 with NEJ120 &
NEJ130 Gyros**

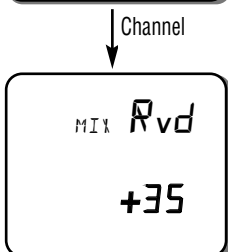
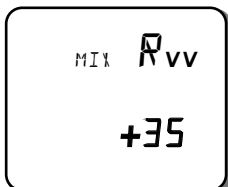

7. Gyro Gain Adjustment

It will be necessary to adjust the "gain" or compensation of the gyro to create the correct amount of "holding power" necessary for a solid neutral tail rotor. The intent of the gyro is to compensate for abrupt movements, or wind direction changes, working in conjunction with the Revolution Mixing Function.

For hovering, it is recommended that you start with the gyro gain at approximately 80%, and continue to increase slightly until the tail of the helicopter "hunts," then reduce the value slightly.

**PCM 10 Series radio with NEJ450,
NEJ900 & NEJ3000 Gyros**



Press SEL to select AUX3 or AUTO GAIN Function

**XP8103 with NEJ450, NEJ900 &
NEJ3000 Gyros**

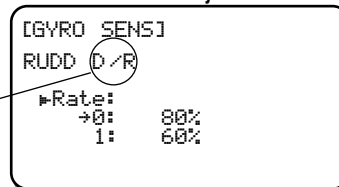

Set to Rudd D/R Switch

(JR NEJ120 only)

Set gain controller values as shown.

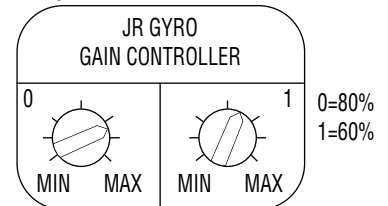

**XP652 with NEJ450,
NEJ900 & NEJ3000 Gyros**

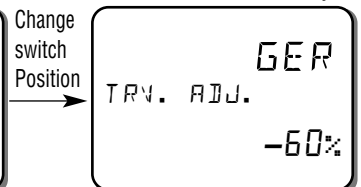
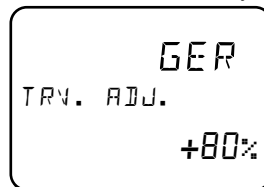

Change switch Position

Please refer to your radio's instructions for more information.

This same adjustment will also be necessary to achieve proper forward flight. Generally, the gyro gain for forward flight will be approximately 10%-20% less than that of the established hover gain due to aerodynamic forces present in forward flight.

If you're using a dual rate gyro, adjust the gain so that you're using "higher" gain setting for hover and the "lower" gain setting for forward flight.

It will also be necessary to confirm the direction the gyro compensates when the body of the helicopter is rotated.

To do this, turn the radio system on and suspend the helicopter by the main rotor head. Next, move the rudder stick to the right and watch the direction that the tail rotor servo arm travels. Now while watching the tail rotor servo arm, rotate the body of the helicopter counterclockwise. The servo arm should move in the same direction as when the rudder stick was moved to the left. If the arm moves in the opposite direction, reverse the gyro and re-test.

FINAL PRE-FLIGHT CHECK

Once all assemblies have been completed, please review the following suggestions before attempting initial flights.

- Review the instruction book and confirm that all assembly steps have been completed thoroughly.
- Check to verify that the tail rotor assembly rotates in the correct direction (see the diagram below).
- Check to insure that all servos are operating smoothly and in the correct direction. Also verify that there is no binding in the control rods

- and that each servo horn is secured with a servo horn mounting screw.
- Verify that the gyro is operational and compensating in the correct direction (detailed in Step 7, page 54).
- Make sure that both the transmitter and receiver have been fully charged (refer to your radio system instructions for proper charging procedures).
- Check to insure that the throttle is working properly and in the correct direction.

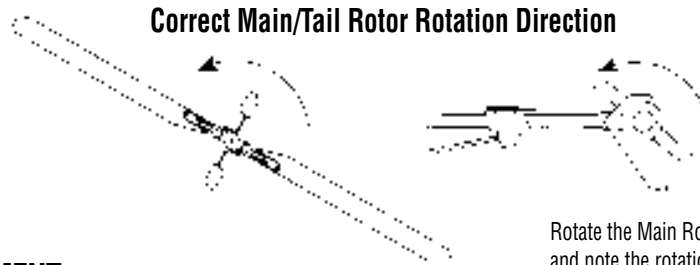

Rotate the Main Rotor counterclockwise (backward) and note the rotation of the Tail Rotor.

BLADE TRACKING ADJUSTMENT

Blade tracking is an adjustment to the main rotor blade pitch that must be accomplished during the initial test flights.

Although the blade pitch angle in each blade may appear equal, it is still possible for a set of main rotor blades to run “out of track,” making adjustment necessary.

Main rotor blades that are out of track with one another can cause vibration, instability, and a loss of power due to additional drag.

On the initial flight, it will be necessary to increase the blade speed to just before lift-off rpm and view the rotor disc at eye level from a safe distance (approximately 15 to 20 feet).

Note which blade is running low (by colored tracking tape) and increase the pitch of the low blade one turn of the ball link at a time until each blade runs in track (on the same plane).

Please refer to the diagrams below to identify the different tracking situations, as well as several methods to mark each rotor blade for tracking identification.

BLADE TRACKING IDENTIFICATION

Out of Track

Incorrect

Adjustment is Necessary

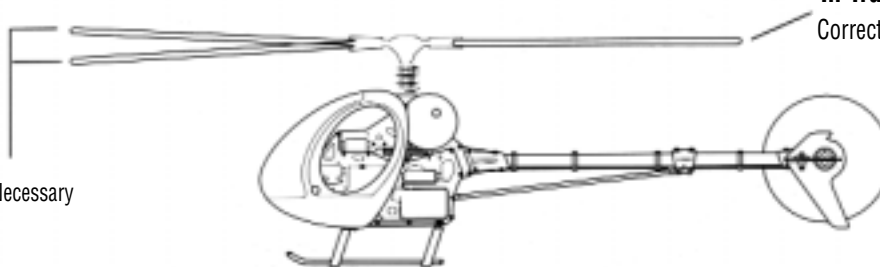

In Track

Correct — Adjustment is **NOT** Necessary

Caution: Be sure to maintain a safe distance from the helicopter (15 to 20 feet) when tracking main rotor blades.

Blade Labeling for Tracking Purposes

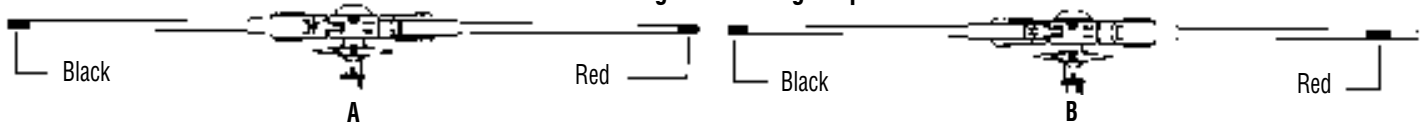

A: Use two different blade tracking tape colors (e.g., black and red) at the tip of each main rotor blade.

B: Use the same color blade tracking tape located at different positions on each rotor blade.

Note: Adding additional blade tracking tape to the rotor blades at this stage will make it necessary to re-static balance the main rotor blades.

Engine

After each day of flying, fully drain the fuel tank. Then, start the engine and let it idle until the engine and the fuel line are completely burned off. It is also suggested that an after-run oil be used to prevent premature engine corrosion.

Tail Rotor Belt

Periodically check the tension on the Tail Drive Belt (as shown in Step 5, page 29) to insure that it has sufficient tension for proper engagement. It is especially important to check this after initial test flights.

Check All Nuts and Bolts

A helicopter is subject to high vibration during flight. It is important to check that all screws, nuts and bolts are properly secured after each day of flying. It is also suggested that you perform a “quick” inspection between each initial test flight for approximately the first 6 to 10 flights.

Check Ball Link Wear

Check to insure that all universal links fit freely but securely to the control balls. If there is excessive play noted, replace the universal link in question.

Battery Maintenance

Check to insure that your batteries are properly mounted and charged. The most frequent cause of crashes (aside from pilot error) is battery failure or disconnection. Be certain that your batteries are fully charged and limit your flight time to 3 or 4 flights between charging. If more flight time is required, purchase a reliable quick field charger.

Cleaning

At the end of each flight or flying session, wipe down your helicopter with a clean towel or rag. This is also a good time to inspect all parts for tightness or fatigue. Remember, a clean, well-maintained helicopter will provide you with many hours of trouble-free flight.

XP652 HELI DATA SHEET ERGO 30SS CCPM INITIAL SET-UP

Modulation S-PCM • Z-PCM • PPM (FM)

Model Number _____

Model Name Ergo 30/SS CCPM Initial Set-Up _____

CHANNEL	THR (1)	AIL (2)	ELE (3)	RUD (4)	GER (5)	PITCH (6)
* REVERSE SW	NORM • REV	NORM • REV	NORM • REV	NORM • REV	NORM • REV	NORM • REV
SUB-TRIM	Adjust as needed					
TRAVEL ADJUST (TRV ADJ.)	Refer to the CCPM section of this manual for proper settings					
FAIL-SAFE (S-PCM)						

FAIL-SAFE TIME (Z-PCM)	
------------------------	--

D/R SW	Factory Pre-Set
--------	-----------------

GEAR SW	Factory Pre-Set
---------	-----------------

THRO HOLD (HLD)	<input checked="" type="radio"/> ON <input type="radio"/> OFF	POSITION
		± Adjust for Idle

REVO-MIX (RV)	+ UP (U)	Refer to Revolution Mixing Section of manual for proper settings
	- DOWN (D)	
HOLD RUDD OFFSET (OFFSET HLD)		±

STUNT TRIM		ON • OFF
AIL (2)	ELE (3)	RUD (4)
+	+	+
-	-	-
Adjust Stunt Trim values as needed		

			AIL (AI)	ELEV (EL)
DUAL RATE	POS 0	D/R	%	%
		EXP	%	%
EXP	POS 1	D/R	%	%
		EXP	%	%

		L	2	H
THRO CURVE TLN, T2N, THN,	N	0%	50%	100%
TLS, T2S	S	40%	60%	
PITCH CURVE PLN, P2N, PHN,	N	-2° Pitch	5° Pitch	10° Pitch
PLS, P2S, PHS,	S	-5° Pitch	5° Pitch	8.5° Pitch
PLH, P2H, PHH	H	-5° Pitch	5° Pitch	13° Pitch

CCPM MIXING		<input checked="" type="radio"/> ON <input type="radio"/> OFF
AIL (2)	ELE (3)	Pitch (6)
<input checked="" type="radio"/> + 60%	<input checked="" type="radio"/> + 60%	<input checked="" type="radio"/> + 50%
<input type="radio"/> -	<input type="radio"/> -	<input type="radio"/> -

		CHANNEL MASTER SLAVE	MIX SWITCH	OFFSET	+GAIN	-GAIN
PROG. MIX	A	→	ON • F1 • F0 • H			

TRIM OFFSET	
-------------	--

XP8103 HELI DATA SHEET ERGO 30SS CCPM INITIAL SET-UP

MODEL NO. _____

MODEL NAME _____

MODULATION SPCM - ZPCM - PPM _____

			AILE	ELEV	RUDD
DUAL-RATE • EXP	0	D/R	90%	90%	90%
		EXP	Adjust as needed		
	1	D/R	100%	100%	100%
		EXP	Adjust as needed		

AUTO D/R (POS. 1)	ST1	INH • ACT
	ST2	INH • ACT
	ST2	INH • ACT

INPUT SEL	AUX2	HOLD SW • PIT.TRIM • INH
	GEAR	ACT • INH

	THRO	AILE	ELEV	RUDD	GEAR	PIT	AUX2	AUX3
REVERSE SW	NORM • REV	NORM • REV	NORM • REV	NORM • REV	NORM • REV	NORM • REV	NORM • REV	NORM • REV
SUB TRIM	Adjust as needed							
TRAVEL ADJUST	Refer to the CCPM section of this manual for proper settings							
FAIL SAFE (SPCM)								

	EXP	L	1	2	3	H	
THROTTLE CURVE	N	OFF•ON	0%	30%	50%	70%	100%
	1	OFF•ON	40%	50%	60%	80%	100%
	2	OFF•ON	Optional				
PITCH CURVE	N	OFF•ON	-2° pitch	%	5° pitch	%	10° pitch
	1	OFF•ON	-5° pitch	%	0° pitch	%	9° pitch
	2	OFF•ON	%	%	%	%	%
	H	OFF•ON	-5° pitch	%	5° pitch	%	13° pitch

GYRO SENS	INH • RUDD D/R • AUTO	0	%
		1	%
		NORM	0
		STNT	1
		HOLD	0
		INVT	1

Refer to gyro gain section for settings

THRO HOLD	INH • ACT	POS Set for idle
THRO HOLD	INH • ACT	OFFSET Adjust as needed

REVO MIX	NORMAL	UP	%
		DOWN	%
	STUNT	UP	%
		DOWN	%
ACC MIX			%

Refer to Revolution Mixing Section of this manual for proper settings

		CHANNEL	SW	EXP	L	1	2	3	H
PROGRAM MIX	MIX1	→		OFF-ON					
	MIX2	→		OFF-ON					
				+POS		-POS		OFFSET	
	MIX3	→		%		%			

Swash Type	1 Servo Norm 2 Servo 180° 3 Servo 120° 4 Servo 90°			
	Aile	Elev	Pit	
Exp Act • INH	± 60%	± 60%	± 50%	

PCM10SXII DATA SHEET
ERGO 30SS CCPM INITIAL SET-UP

MODEL NO. (84) _____

MODEL NAME (81) ERGO 30SS _____

MODULATION (85) SPCM-ZPCM-PPM _____

	THRO	AILE	ELEV	RUDD	GEAR	PITCH	AUX2	AUX3	AUX4	AUX5
REVERSE SW (11)	(R) N	(R) N	R (N)	(R) N	R (N)	R (N)	R (N)	R (N)	R (N)	R (N)
TRAVEL ADJUST (12)	Refer to the CCPM section of this manual for proper settings									
SUB-TRIM (15)	Adjust as needed									
TRIM RATE (83)	100%	100%	100%	50%						

			AILE	ELEV	RUDD
D/R EXP (13)	0	D/R	90%	90%	70%
		EXP	Adjust as needed		
		TYPE			
	1	D/R	100%	100%	100%
		EXP	Adjust as needed		
		TYPE			
	2	D/R	Optional		
		EXP			
		TYPE			
AUTO D/R (23)	ST-1	INH • (ACT)	0 • (1) • 2	0 • (1) • 2	0 • (1) • 2
	ST-2	INH • ACT	0 • 1 • 2	0 • 1 • 2	0 • 1 • 2
	ST-3	INH • ACT	0 • 1 • 2	0 • 1 • 2	0 • 1 • 2
	ST-4	INH • ACT	0 • 1 • 2	0 • 1 • 2	0 • 1 • 2
	HOLD	INH • (ACT)	0 • (1) • 2	0 • (1) • 2	0 • (1) • 2
STUNT TRIM (25)	ST-1	INH • (ACT)	Adjust as necessary during flight.		
	ST-2	INH • (ACT)			
	ST-3	INH • ACT			
	ST-4	INH • ACT			

THROTTLE HOLD (16)	HOLD SW	INH • (HOLD) GEAR
	POS	Adjust for Idle
	AUTO CUT	(INH) • ACT POS

FUNCTION SELECT (16)	FLIGHT EXTRA	(INH) • GEAR AILE
	GEAR SW	(INH) • GEAR HOLD
	INVERTED SW	(INH) • INVT HOLD
	PIT. LEVER	LOW
HI		(INH) • ACT

4 → 1 MIX (41)	R	%
	L	%
	MIX SW	INH • ACT

GYRO SENS (44)	INH AUX 3 AUTO	0	Refer to the Gyro Gain Mixing Section of this manual for proper settings						
		1							
		2							
	NR	S1	S2	S3	S4	HD	INV		
	0	1						1	

		CHANNEL		TRIM	SW	OFFSET		+GAIN				-GAIN			
		MASTER	SLAVE			EXP	L	1	2	3	4	5	6	H	
PROGRAM MIX (51) - (58)	1	INH ACT	→	OFF ON	NR•S1•S2•S3•S4 HD•AX2•GER										
	2	INH ACT	→	OFF ON	NR•S1•S2•S3•S4 HD•AX2•GER										
	3	INH ACT	→	OFF ON	NR•S1•S2•S3•S4 HD•AX2•GER										
	4	INH ACT	→	OFF ON	NR•S1•S2•S3•S4 HD•AX2•GER										
	5	INH ACT	→	OFF ON	NR•S1•S2•S3•S4 HD•AX2•GER	OFF ON	IN OUT	0							100
	6	INH ACT	→	OFF ON	NR•S1•S2•S3•S4 HD•AX2•GER	OFF ON	IN OUT	0							100
	7	INH ACT	→	OFF ON	NR•S1•S2•S3•S4 HD•AX2•GER	OFF ON	IN OUT	0							100
	8	INH ACT	→	OFF ON	NR•S1•S2•S3•S4 HD•AX2•GER	OFF ON	IN OUT	0							100

PCM10SXII DATA SHEET

ERGO 30SS INITIAL SET-UP CONTINUED

		EXP		L	1	2	3	4	5	6	H	
THRO CURVE (18) TH,TRIM=SLOW HOV.T=CENTER	N	OFF	IN	0							100	
		<input checked="" type="radio"/>	OUT	0			50% Power				100%	
			HOV.SEL	—		HOV	HOV	<input checked="" type="radio"/>	HOV	HOV	HOV	—
	1	OFF	IN	0				50				100
		<input checked="" type="radio"/>	OUT	40%				60%				100%
	2	OFF	IN	0								100
		<input checked="" type="radio"/>	OUT									100%
	3	OFF	IN	0								100
		<input checked="" type="radio"/>	OUT									
	4	OFF	IN	0								100
		<input checked="" type="radio"/>	OUT									
	PITCH CURVE (68) P,TRIM=CENTER HOV.P=CENTER	N	OFF	IN	0							100
<input checked="" type="radio"/>			OUT	-2° Pitch			5° Pitch				10° Pitch	
			HOV.SEL	—		HOV	HOV	HOV	HOV	HOV	HOV	—
1		OFF	IN	0								100
		<input checked="" type="radio"/>	OUT	-5° Pitch				5° Pitch				9° Pitch
2		OFF	IN	0								100
		<input checked="" type="radio"/>	OUT									
3		OFF	IN	0								100
		<input checked="" type="radio"/>	OUT									
4		OFF	IN	0								100
		<input checked="" type="radio"/>	OUT									
HOLD		OFF	IN	0								100
	<input checked="" type="radio"/>	OUT	-5° Pitch				5° Pitch				13° Pitch	

TAIL ROTOR CURVE (47)	N	<input checked="" type="radio"/> RIGHT	LEFT	UP	%	DN	%	HOV. POS.							
								L	1	2	3	4	5	6	H
1	NOR	IN	0												100
	ORG	OUT		Refer to the Revolution Mixing Section of this manual for proper settings											
2	NOR	IN	0												100
	ORG	OUT		Refer to the Revolution Mixing Section of this manual for proper settings											
3	NOR	IN	0												100
	ORG	OUT		Refer to the Revolution Mixing Section of this manual for proper settings											
4	NOR	IN	0												100
	ORG	OUT		Refer to the Revolution Mixing Section of this manual for proper settings											
STUNT MIX RATE		1/1 • 1/2 • 1/4 • 1/10													

TRIM OFFSET (82)	HV.T	HV.P	LO.P	HI.P	AIL	ELEV	RUDD

Rudder→Throttle 4→1 MIX (41)	R	%
	L	%
MODE SELECTION	NR • S1 • S2 • S3 • S4 • AX2	

Aileron→Throttle 2→1 MIX (41)	R	%
	L	%
MODE SELECTION	NR • S1 • S2 • S3 • S4 • AX2	

	U	
	D	
MODE SELECTION	NR • S1 • S2 • S3 • S4 • AX2	

FAIL- SAFE (77)	Z	MODE	HOLD • 1.0s • 0.5s • 0.25s
	S	MEMORY	

PILOT LINK (78)	INH • MST • SLV
-----------------	-----------------

SWASHPLATE MIXING TYPE (65)	1 SERVO • 3SERVO • 120°CCPM					
	1SERVO	ELE → AIL	D	%		
			U	%		
	AIL → ELE	L	%			
R		%				
SWITCH	NR • S1 • S2 • S3 • S4 • HD					
3 SERVO 120° CCPM	AIL	+60%	ELE	+60%	PIT	-50%

10X HELI DATA SHEET
ERGO 30SS CCPM INITIAL SET-UP

MODEL NO. (84) _____

MODEL NAME (81) _____

MODULATION (85) SPCM-ZPCM-PPM _____

	THRO	AILE	ELEV	RUDD	GEAR	PITCH	AUX2	AUX3	AUX4	AUX5
REVERSE SW	$\begin{matrix} R \\ N \end{matrix}$	$\begin{matrix} R \\ N \end{matrix}$	$\begin{matrix} R \\ N \end{matrix}$	$\begin{matrix} R \\ N \end{matrix}$	$\begin{matrix} R \\ N \end{matrix}$	$\begin{matrix} R \\ N \end{matrix}$	$\begin{matrix} R \\ N \end{matrix}$	$\begin{matrix} R \\ N \end{matrix}$	$\begin{matrix} R \\ N \end{matrix}$	$\begin{matrix} R \\ N \end{matrix}$
TRAVEL ADJUST (12)	Refer to the CCPM section of this manual for proper settings									
SUB-TRIM (15)	Adjust as needed									
TRIM RATE (83)	%									

			AILE	ELEV	RUDD
D/R EXP (13)	0	D/R	90%	90%	90%
		EXP	Adjust as needed		
		TYPE			
	1	D/R	100%	100%	100%
		EXP	Adjust as needed		
		TYPE			
2	D/R	Optional			
	EXP				
	TYPE				
AUTO D/R (23)	ST-1	$\text{INH} \cdot \text{ACT}$	0 · ① · 2	0 · ① · 2	0 · ① · 2
	ST-2	$\text{INH} \cdot \text{ACT}$	0 · 1 · 2	0 · 1 · 2	0 · 1 · 2
	ST-3	$\text{INH} \cdot \text{ACT}$	0 · 1 · 2	0 · 1 · 2	0 · 1 · 2
	ST-4	$\text{INH} \cdot \text{ACT}$	0 · 1 · 2	0 · 1 · 2	0 · 1 · 2
	HOLD	$\text{INH} \cdot \text{ACT}$	0 · ① · 2	0 · ① · 2	0 · ① · 2

THROTTLE HOLD (16)	HOLD SW	$\text{INH} \cdot \text{HOLD} \cdot \text{GEAR}$
	POS	Adjust for Idle
	AUTO CUT	$\text{INH} \cdot \text{ACT}$
	Delay	1/4 ①/2 3/4 1

FUNCTION SELECT (17)	FLIGHT EXTRA	$\text{INH} \cdot \text{GEAR} \cdot \text{AILE}$	
	GEAR SW	$\text{INH} \cdot \text{GEAR} \cdot \text{HOLD}$	
	AUX2 SW	$\text{INH} \cdot \text{ACT}$	
	PIT. LEVER	LOW	$\text{INH} \cdot \text{ACT}$
		HI	$\text{INH} \cdot \text{ACT}$
	ADT STUNT	$\text{INH} \cdot \text{ACT}$	

GYRO SENS (44)	$\text{INH} \cdot \text{AUX} 3 \cdot \text{AUTO}$	0	Refer to the Gyro Gain Section of this manual for proper settings					
		1						
		2						
		NR S1 S2 S3 S4 HD	0	1				1

		CHANNEL		TRIM	SW	OFFSET			+GAIN				-GAIN			
		MASTER	SLAVE			EXP	L	1	2	3	4	5	6	H		
PROGRAM MIX (51) - (58)	1	$\text{INH} \cdot \text{ACT}$	→	OFF · ON	NR·S1·S2·S3·S4 HD·AX2·GER											
	2	$\text{INH} \cdot \text{ACT}$	→	OFF · ON	NR·S1·S2·S3·S4 HD·AX2·GER											
	3	$\text{INH} \cdot \text{ACT}$	→	OFF · ON	NR·S1·S2·S3·S4 HD·AX2·GER											
	4	$\text{INH} \cdot \text{ACT}$	→	OFF · ON	NR·S1·S2·S3·S4 HD·AX2·GER											
	5	$\text{INH} \cdot \text{ACT}$	→	OFF · ON	NR·S1·S2·S3·S4 HD·AX2·GER	OFF · ON	IN	0								100
	6	$\text{INH} \cdot \text{ACT}$	→	OFF · ON	NR·S1·S2·S3·S4 HD·AX2·GER	OFF · ON	IN	0								100
	7	$\text{INH} \cdot \text{ACT}$	→	OFF · ON	NR·S1·S2·S3·S4 HD·AX2·GER	OFF · ON	IN	0								100
	8	$\text{INH} \cdot \text{ACT}$	→	OFF · ON	NR·S1·S2·S3·S4 HD·AX2·GER	OFF · ON	IN	0								100

10X HELI DATA SHEET

ERGO 30SS CCPM INITIAL SET-UP

		EXP		L	1	2	3	4	5	6	H	
THRO CURVE (18) TH,TRIM=SLOW HOV.T=CENTER	N	OFF ON	IN	0							100	
			OUT	0				50%			100	
			HOV.SEL	—	HOV	HOV	HOV	HOV	HOV	HOV	HOV	—
	1	OFF ON	IN	0								100
			OUT	40%				60%				100
	2	OFF ON	IN	0								100
			OUT									
	3	OFF ON	IN	0								100
			OUT									
	4	OFF ON	IN	0								100
			OUT									
	PITCH CURVE (68) P,TRIM=CENTER HOV.P=CENTER	N	OFF ON	IN	0							100
OUT				-2°Pitch				5°Pitch			10°Pitch	
HOV.SEL				—	HOV	HOV	HOV	HOV	HOV	HOV	HOV	—
1		OFF ON	IN	0								100
			OUT	-5°Pitch				5°Pitch				9°Pitch
2		OFF ON	IN	0								100
			OUT									
3		OFF ON	IN	0								100
			OUT									
4		OFF ON	IN	0								100
			OUT									
HOLD		OFF ON	IN	0								100
	OUT		-5°Pitch				5°Pitch				13°Pitch	

TAIL ROTOR CURVE (47)	N	NOR	IN	L	1	2	3	4	5	6	H
		ORG	OUT								
1	NOR	IN	0								100
		ORG	OUT								
2	NOR	IN	0								100
		ORG	OUT								
3	NOR	IN	0								100
		ORG	OUT								
4	NOR	IN	0								100
		ORG	OUT								
MIX RATE		1/1 • 1/2 • 1/4 • 1/10									

Refer to Revolution Mixing
Section of this manual for
proper settings

TRIM OFFSET (82)	HV.T	HV.P	LO.P	HI.P

Rudder→Throttle 4→1 MIX (41)	R	%
	L	%
MODE SELECTION	NR • S1 • S2 • S3 • S4 • AX2	

FAIL-SAFE (77)	Z	MODE	HOLD • 1.0s • 0.5s • 0.25s
		MEMORY	
	S	MEMORY	

Aileron→Throttle 2→1 MIX (41)	R	%
	L	%
MODE SELECTION	NR • S1 • S2 • S3 • S4 • AX2	

SWASHPLATE MIXING TYPE (65)	1 SERVO • 3SERVO - 120°CCPM • 3SERVO - 140°CCPM					
	1SERVO	ELE → AIL	D	%		
			U	%		
		AIL → ELE	L	%		
R			%			
SWITCH	NR • S1 • S2 • S3 • S4 • HD					
3 SERVO 120° CCPM	AIL	+60%	ELE	+60%	PIT	+50%
3 SERVO 140° CCPM	AIL	%	ELE	%	PIT	%

Elevator→Throttle 3→1 MIX (41)	U	%
	D	%
MODE SELECTION	NR • S1 • S2 • S3 • S4 • AX2	

ROTOR HEAD ASSEMBLY

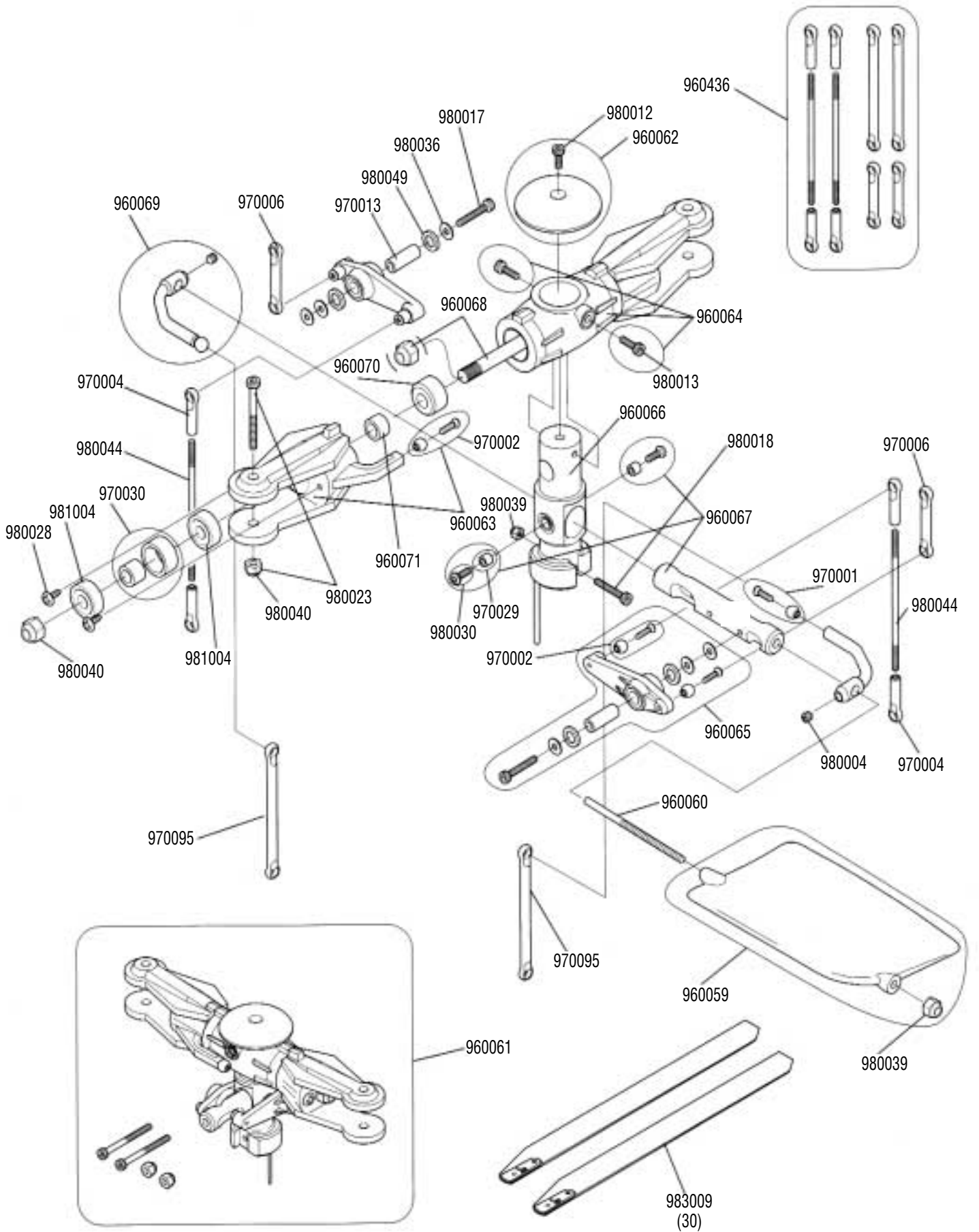

ROTOR HEAD ASSEMBLY PARTS LIST

PART #	DESCRIPTION	QUANTITY	COMMENTS /ADDITIONAL CONTENTS
JRP960436	Linkage Set	1	
JRP980012	Socket Head Bolts, 3x6mm	10	
JRP960062	Head Button	1	1 - 3x6mm Socket Head Bolt
JRP980017	Socket Head Bolts, 3x16mm	10	
JRP980036	Plate Washers, 3mm	1	
JRP980049	Nylon Washer .5	10	
JRP970013	Mixing Arm Bushing	2	
JRP970006	Double Link	4	
JRP960069	Flybar Control Arm	2	2 - 4mm Set Screws
JRP960064	Main Rotor Body	1	2 - 3x8mm Socket Head Bolts
JRP960068	Blade Spindle Shaft	1	2 - 4mm Lock Nuts
JRP960070	Blade Damper Rubber	4	
JRP970004	Universal Ball Links	10	
JRP980044	Control Rod, 2.3x40mm	1	
JRP970002	Steel Joint Ball w/ 2x10mm Screw	10	10 - 2x10mm Flat Head Screws
JRP980013	Socket Head Bolts, 3x8mm	10	
JRP960066	Main Rotor Hub	1	
JRP980018	Socket Head Bolts, 3x18mm	10	
JRP980039	Nylon Lock Nuts, 3mm	10	
JRP960063	Main Blade Holder	2	2 - 2x10mm Flat Head Screws 2 - Steel Joint Balls
JRP960071	Blade Holder Spacer A	2	
JRP970030	Main Blade Bearing Spacer	2	2 - Inner Bearing Spacers 2 - Outer Bearing Spacers
JRP981004	Main Blade Holder Bearings	2	
JRP980028	Self Tapping Screws, 3x6mm	10	
JRP980040	Nylon Lock Nuts, 4mm	10	
JRP970029	Seesaw Spacer Collar	2	
JRP980030	Button Head Bolts, 3x5mm	10	
JRP960067	Seesaw Shaft	1	
JRP970001	Joint Balls/2x8mm Screws	10	
JRP980044	Control Rod	1	
JRP980004	Set Screws, 4x4mm	10	
JRP970002	Joint Balls/2x10mm Screws	10	
JRP960065	Seesaw Mixing Arm	1	
JRP960060	Flybar	1	
JRP970095	Double Link, Long	1	
JRP960059	Flybar Paddles	1	
JRP980039	Main Rotor Blade, White 550mm	1	
JRP960061	Rotor Head Assembly	1	

WASHOUT UNIT/CCPM CONTROL SYSTEM ASSEMBLY

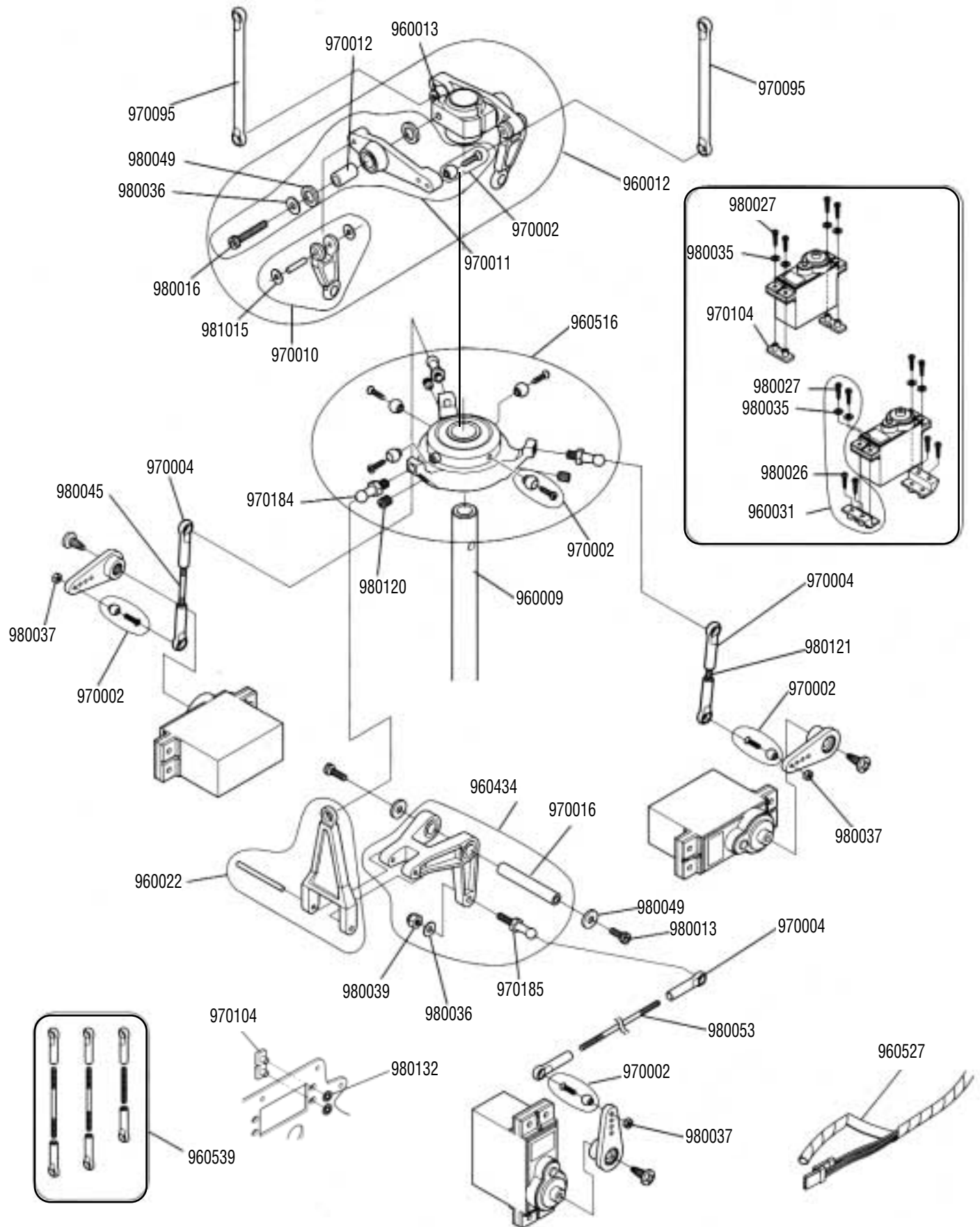

WASHOUT UNIT/CCPM CONTROL SYSTEM PARTS LIST

PART #	DESCRIPTION	QUANTITY	COMMENTS /ADDITIONAL CONTENTS
JRP970095	Double Link, Long	1	
JRP970012	Washout Arm Bushing	2	
JRP960013	Washout Base	1	
JRP960012	Washout Assembly	1	Complete w/ All Components
JRP970002	Steel Joint Ball w/2x10mm Screw	10	10 - 2x10mm Flat Head Screws
JRP970010	Washout Link	2	2 - Washout Link Pins
JRP980049	Nylon Washer .5	10	
JRP980036	Plate washers, 3mm	10	
JRP980016	Socket Head Bolts, 3x15mm	10	
JRP981015	CA Stopper Ring, 2mm	1	
JRP960516	Swashplate Assembly	1	Complete With All Hardware
JRP970184	Ball Arm, 9mm	1	
JRP980120	4X4mm Set Screw	10	
JRP960009	Main Rotor Shaft	1	
JRP980027	Self Tapping Screws, 2.6x12mm	10	
JRP980053	Plate Washers, 2.6mm	1	
JRP970104	Servo Mounting Plate	1	
JRP380035	Plate Washers, 2.6mm	10	
JRP980026	Self Tapping Screws, 2.6x8mm	10	
JRP960031	Servo Mounting Plate	1	
JRP970004	Universal Ball Links	10	
JRP980121	Control Rod, 2.3x25mm	1	
JRP980037	Hex Nuts, 2mm	10	
JRP980045	Control Rod, 2.3x45mm	1	
JRP960022	Swashplate A Arm	2	Complete w/ 2-A Arms & Pins
JRP960434	Elevator Arm Assembly	1	
JRP970016	Elevator Arm Bushing	2	
JRP980039	Nylon Lock Nuts, 3mm	10	
JRP970185	Ball Arm, 11mm	1	
JRP980013	Socket Head Bolts, 3x8mm	10	
JRP980053	Control Rods. 2.3x50mm	2	
JRP960539	Linkage Set	1	
JRP960527	Spiral Wire Wrap	1	
JRP980132	Star Washer	10	

UPPER MAIN FRAME/BODY SET/MAIN GEAR ASSEMBLY

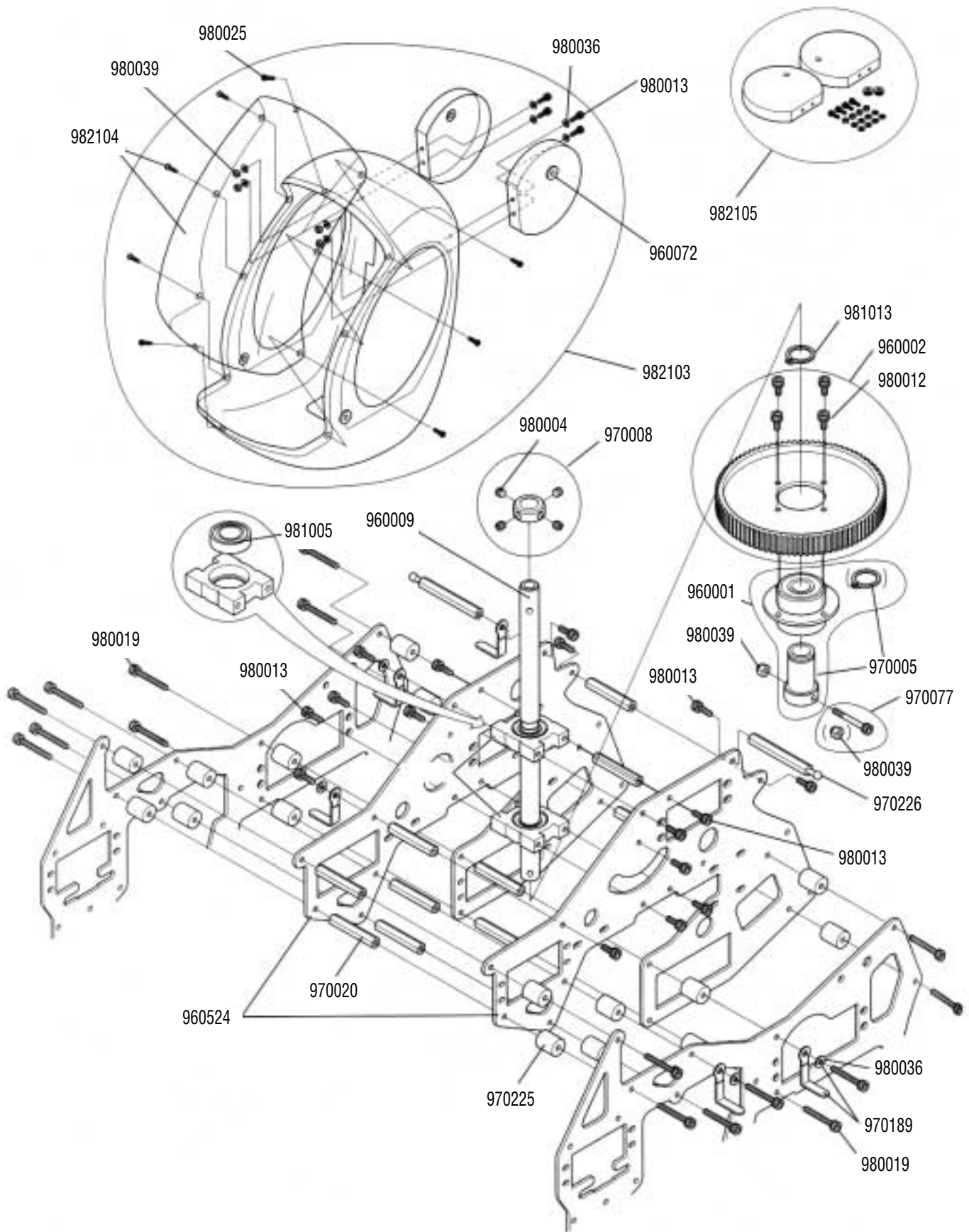

UPPER MAIN FRAME/BODY SET/MAIN GEAR ASSEMBLY PARTS LIST

PART #	DESCRIPTION	QUANTITY	COMMENTS /ADDITIONAL CONTENTS
JRP980025	Self Tapping Screws, 2.3x8mm	10	
JRP982104	Ergo 30SS Canopy	1	5 - 2.3x8mm Self Tapping Screws
JRP960072	Rubber Grommets	4	
JRP982001	Body Set	1	Complete w/Canopy & Hardware
JRP981005	Bearing, 1910ZZ	1	
JRP980004	Set Screws, 4x4mm	10	
JRP970008	Main Shaft Collar	1	4 - 4x4mm Set Screws
JRP980013	Socket Head Bolts, 3x8mm	10	
JRP960009	Main Rotor Shaft	1	
JRP980019	Socket Head Bolts, 3x22mm	10	
JRP981013	C Stopper Ring	1	
JRP960002	Main Drive Gear 88T	1	4 - 3x6mm Socket Head Screws
JRP980012	Socket Head Bolts, 3x6mm	10	
JRP960001	Autorotation Assembly	1	4 - 3x6mm Socket Head Screws
JRP970005	Autorotation Shaft Hub Sleeve	1	Complete w/ Clip
JRP980039	Nylon Lock Nuts, 3mm	10	
JRP960522	Main Shaft Bearing Block	1	Complete w/ Bearing
JRP970020	Main Frame Standoff, 32mm	2	
JRP960524	Upper Main Frame	1	
JRP980036	Flat Washer, 3mm	10	
JRP982105	Body Tank, 30SS	2	
JRP982103	Body Set, 30SS	1	Complete w/Canopy, Tanks, and Hardware
JRP981013	C Stopper Ring	10	
JRP970077	Main Rotor Shaft Bolts	2	
JRP970226	Body Mount Standoff, 50mm	2	
JRP970225	Frame Spacer, 12mm	2	
JRP970189	Servo Wire Holders	2	

LOWER MAIN FRAME/LANDING GEAR/FUEL TANK ASSEMBLY

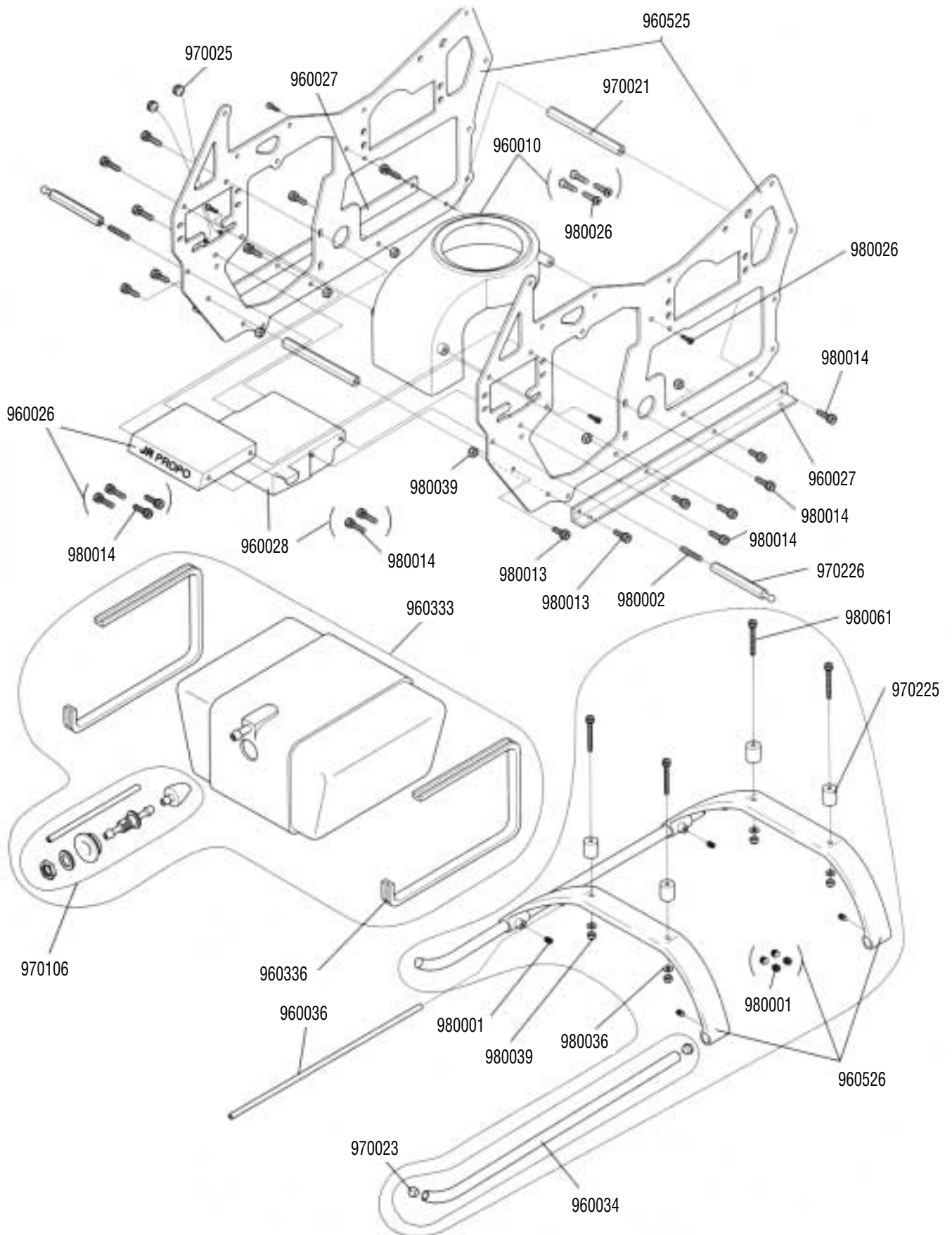

LOWER MAIN FRAME/LANDING GEAR/FUEL TANK PARTS LIST

PART #	DESCRIPTION	QUANTITY	COMMENTS /ADDITIONAL CONTENTS
980026	Self Tapping Screw, 2.6x8mm	10	
980014	Socket Head Bolt, 3x10mm	10	
980039	Nylon Lock Nuts, 3mm	10	
970106	Fuel Tank Fitting Set	1	
960336	Tank Mounting Rubber	2	
980001	Set Screw, 3x4mm	10	
980036	Flat Washer, 3mm	10	
970225	Frame Spacer, 12mm	2	
980061	Socket Head Bolt, 3x25mm	10	
970226	Body Mount Standoff, 50mm	2	
980013	Socket Head Bolt, 3x8mm	10	
980002	Set Screw, 3x18mm	10	

TAIL BOOM/TAIL BRACE/TAIL BOOM CARRIER ASSEMBLY

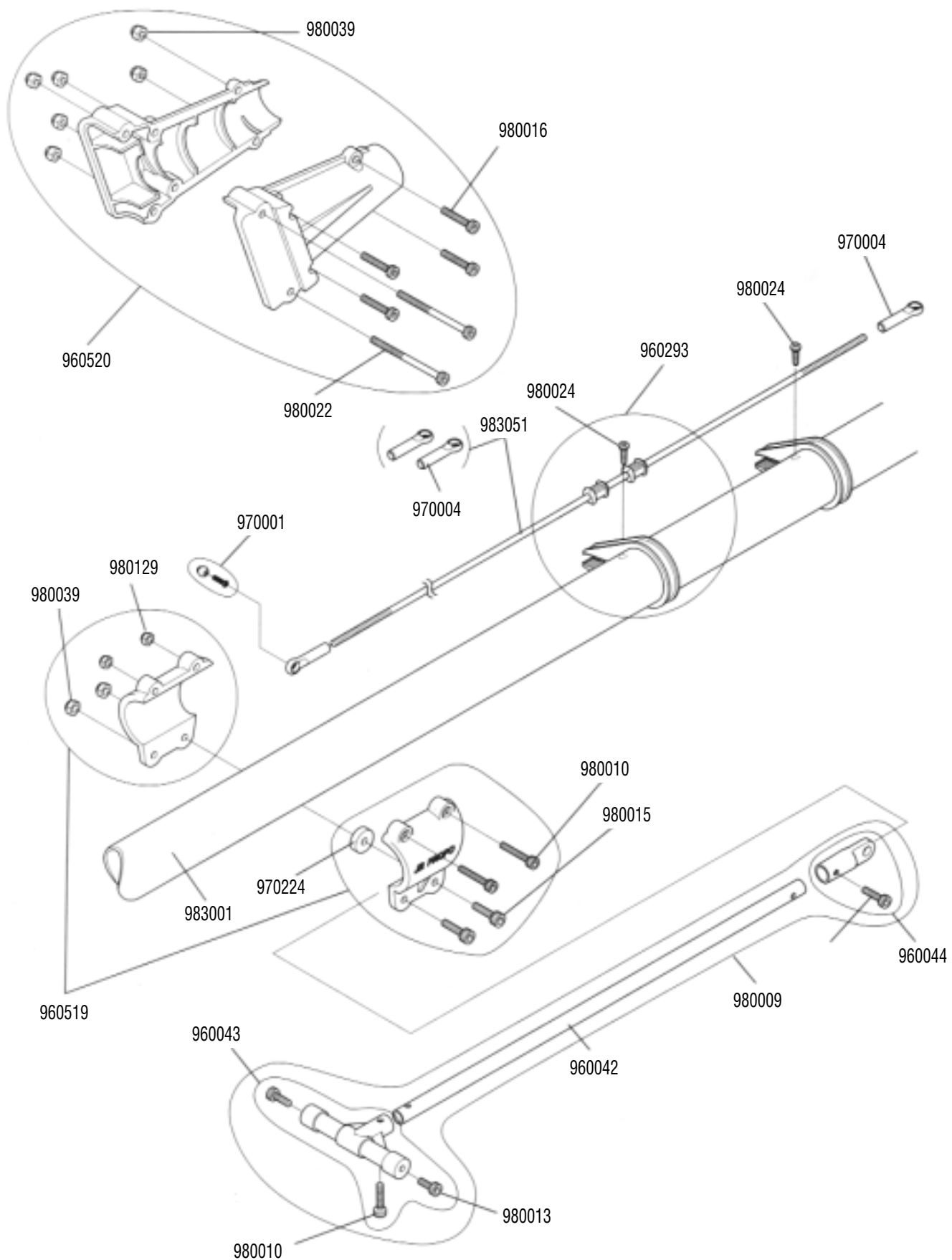

TAIL BOOM/TAIL BRACE/TAIL BOOM CARRIER PARTS LIST

PART #	DESCRIPTION	QUANTITY	COMMENTS /ADDITIONAL CONTENTS
JRP960041	Tail Brace Set	1	1 - Tail Brace Tube 1 - Tail Brace Connector 1 - Tail Brace T End 1 - 2.6x12mm Socket Head Bolt 1 - 2.6x15mm Socket Head Bolt
JRP960042	Tail Brace Tube	1	
JRP960043	Tail Brace T End	1	2 - 3x8mm Socket Head Bolts 1 - 2.6x15mm Socket Head Bolt
JRP960044	Tail Brace Connector	1	1 - 2.6x12mm Socket Head Bolt
JRP960519	Tail Brace Clamp	1	Complete w/all hardware
JRP960520	Tail Boom Carrier	1	2 - 3x40mm Socket Head Bolts 4 - 3x15mm Socket Head Bolts 6 - 3mm Lock Nuts
JRP960293	Tail Rod Guide Set	4	4 - Tail Rod Guides 5 - Tail Rod Guide Collars 1 - Tail Control Rod Guide 4 - 2x8mm Self Tapping Screws 1 - 3x10mm Socket Head Bolt
JRP983001	Tail Boom	1	
JRP983051	Tail Control Rod	1	
JRP980039	3mm Lock Nut	10	
JRP980016	Socket Head Bolts, 3x15mm	10	
JRP980024	Self Tapping Screws, 2x8mm	10	
JRP970004	Universal Ball Link	10	
JRP980022	Socket Head Bolts, 3x40mm	10	
JRP980015	Socket Head Bolts, 3x12mm	10	
JRP980009	Socket Head Bolts, 2.6x12mm	10	
JRP980010	Socket Head Bolts, 2.6x15mm	10	
JRP970001	Joint Ball w/Screw 2x8mm	10	
JRP980129	Lock Nut, 2.6mm	10	
JRP970224	Plastic Spacer, 3x7x3mm	2	
JRP980013	Socket Head Bolts, 3x8mm	10	

TAIL ROTOR ASSEMBLY

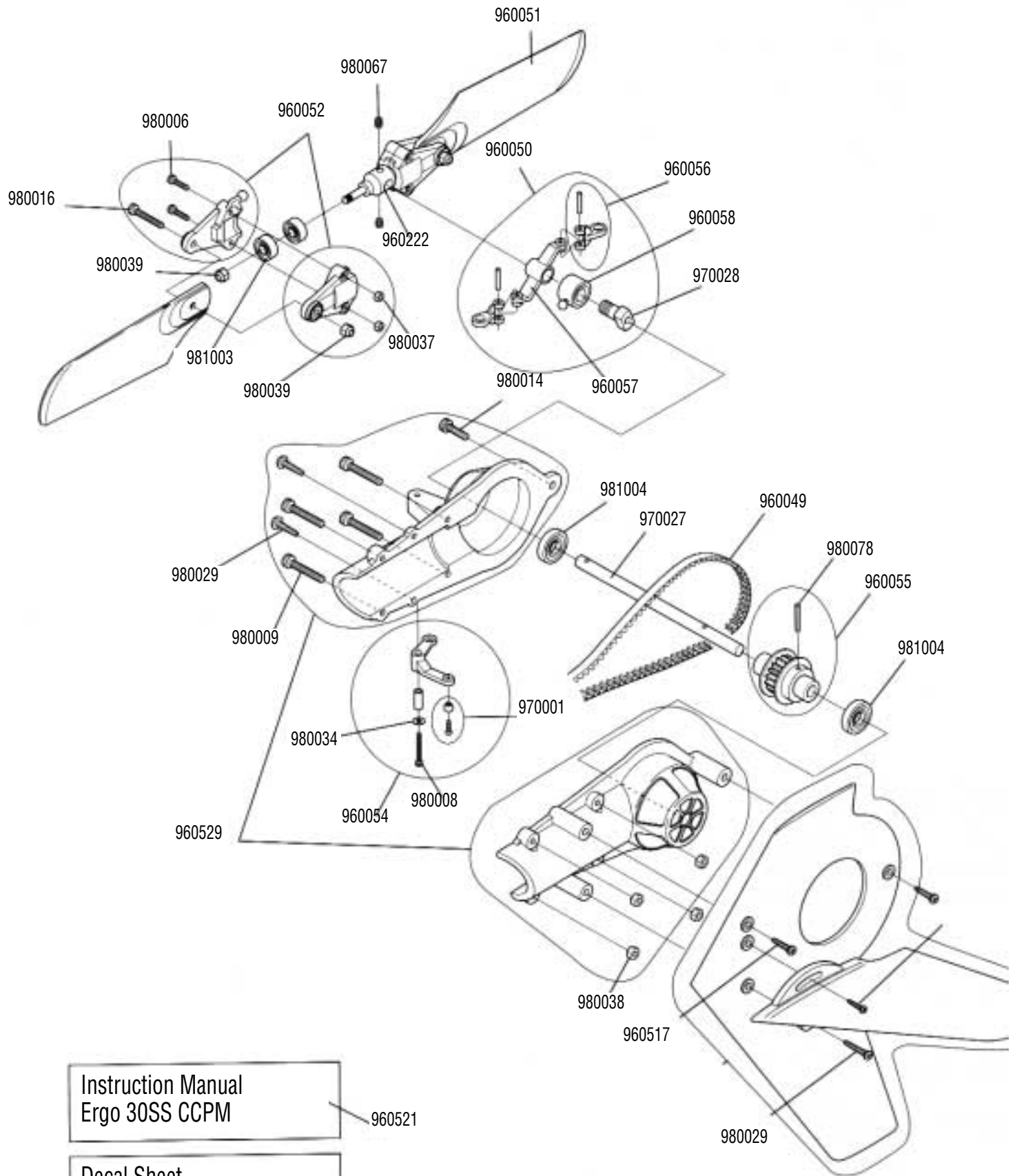

TAIL ROTOR ASSEMBLY PARTS LIST

PART #	DESCRIPTION	QUANTITY	COMMENTS /ADDITIONAL CONTENTS
JRP960517	Tail Fin Set	1	1 - Horizontal Fin 1 - Vertical Fin 3 - 3x12mm Self Tapping Screws 2 - 3x12mm Socket Head Bolts
JRP960049	Tail Drive Belt	1	
JRP960050	Tail Slide Ring Assembly	1	Complete w/ All Components
JRP960051	Tail Rotor Blades	2	
JRP960052	Tail Blade Holder Set	2	2 - 3x15mm Socket Head Bolts 4 - 2x8mm Socket Head Bolts 2 - 3mm Lock Nuts 4 - 2mm Hex Nuts
JRP960529	Tail Case Set (L&R)	1	4 - 2.6x12mm Socket Head Bolts 4 - 2.6mm Hex Nuts 1 - 3x10 Socket Head Bolt
JRP960054	Tail Pitch Control Lever	1	1 - Lever Bushing 1 - 2x20mm Socket Head Bolt 1 - 2mm Flat Washer 1 - Steel Joint Ball 1 - 2x8mm Flat Head Screw
JRP96055	Tail Case Pulley	1	1 - Pressure Pin
JRP960056	Tail Pitch Link	2	Complete w/ 2 Link Pins
JRP960057	Tail Pitch Plate	2	
JRP960058	Tail Slide Ring	1	Complete w/ Bearing
JRP960521	Ergo 30SS CCPM Assembly Manual	1	
JRP970001	Steel Joint Ball w/2x8mm Screw	10	10 - 2x8mm Flat Head Screws
JRP960222	Tail Center Hub	1	2- 3mm Set Screws
JRP970027	Tail Output Shaft	1	
JRP970028	Tail Slide Ring Sleeve	1	
JRP981003	Tail Blade Holder Bearing	2	
JRP980067	Set Screws, 3x3mm	10	
JRP980006	Socket Head Bolts, 2x8mm	10	
JRP980016	Socket Head Bolts, 3x15mm	10	
JRP980039	Nylon Lock Nuts, 3mm	10	
JRP980037	Hex Nuts, 2mm	10	
JRP980014	Socket Head Bolts, 3x10mm	10	
JRP980029	Self Tapping Screws, 3x12mm	10	
JRP980009	Socket Head Bolts, 2.6x12mm	10	
JRP980034	Plate Washers, 2mm	10	
JRP980008	Socket Head Bolts, 2x20mm	10	
JRP980078	Tail Pulley Spring Pin		
JRP980038	Hex Nuts, 2.6mm	10	
JRP980029	Self Tapping Screws, 3x12mm	10	
JRP960540	Decal Sheet, Ergo 30SS CCPM	1	
JRP981004	Ball Bearings, 5x13x4mm	2	

NOTES

